

# TANDEM plus 562H full extension drawer runners

## Overlay application

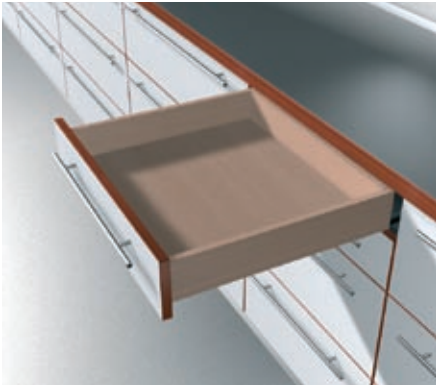

## Description

- Full extension concealed drawer runners
- Available with integrated BLUMOTION
- For **16** (5/8") max. drawer side thickness
- Rear tilt adjustment
- Concealed roller carriages with permanently lubricated synthetic rollers create a smooth running action
- Locking devices enable easy drawer insertion and removal
- Force guided right side and  $\pm 1.5$  (1/16") tolerance compensating left side
- Dynamic weight capacity of 75 lb
- Static weight capacity of 100 lb

## Basic components

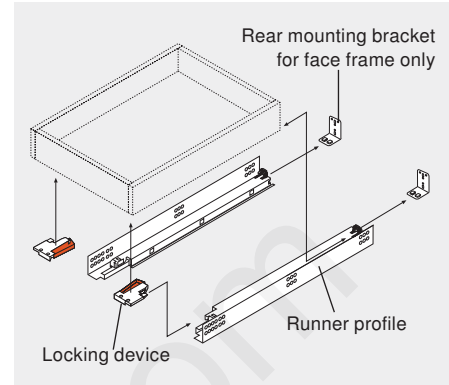

## Other applications

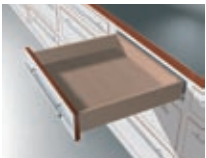

Inset drawer **pg. 27**

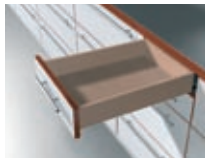

Narrow drawer **pg. 29**



Roll-out tray **pg. 31**

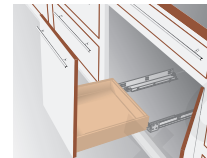

Bottom mount **pg. 32**



ORGA-LINE **pg. 35**



Deep drawer **pg. 39**

## Components

### Profile set

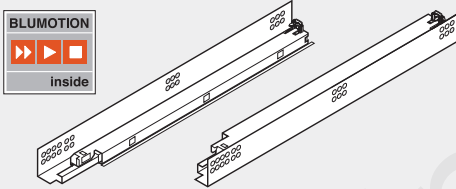

One set required per drawer

For overall cabinet depth	Drawer length	Over extension	TANDEM plus	TANDEM plus BLUMOTION
381 (15")	305 (12")	0	562H3050C	562H3050B
457 (18")	381 (15")	0	562H3810C	562H3810B
533 (21")	457 (18")	6 (1/4")	562H4570C	562H4570B
610 (24")	533 (21")	16 (5/8")	562H5330C	562H5330B

**Note:** These runners are for **16** (5/8") max. drawer side thickness

### Standard locking device

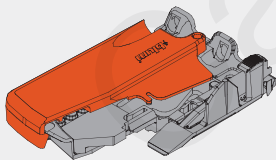

- One right and one left required per drawer
- Minimum interior drawer width **121** (4-3/4")
- Height adjustable +3 (1/8")

Installation <b>page 14</b>	Right	T51.1700.04 R
	Left	T51.1700.04 L
	Installation screws	612TH

### Rear mounting bracket for frame cabinets

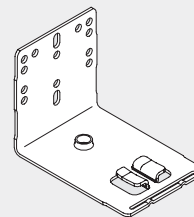

For use when installing TANDEM runners in face frame cabinets. Not necessary for panel cabinet installation.

- Two required per drawer
- Depth and side-to-side self-alignment
- Zinc-plated steel

Non-handed bracket	295.3750
Installation screws	612TH

Using TANDEM

**page 13**

Drawer preparation

**page 14**

Accessories

**page 45**

Assembly aids

**page 47**

Extension	<b>Full</b>
Max. drawer material	<b>16 (5/8")</b>
Dynamic capacity	<b>75 lb.</b>
Static capacity	<b>100 lb.</b>

## Drawer and cabinet specifications

### Front view

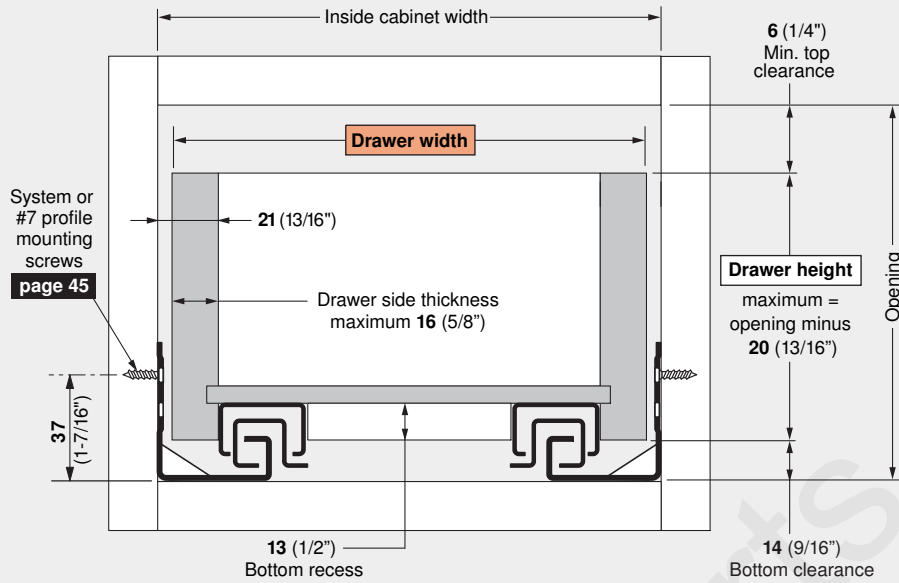

System or #7 profile mounting screws  
page 45

### Drawer back preparation

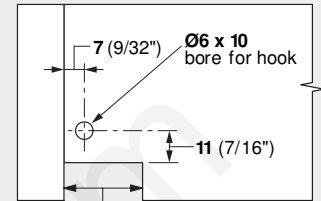

33 (1-5/16") minimum rear notch

### Rear mounting bracket

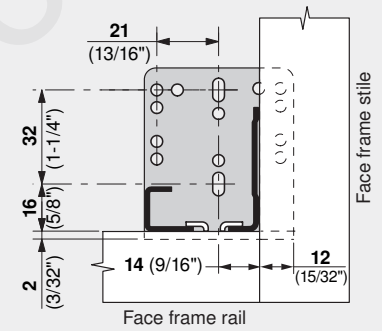

**Note:** For frame applications.  
Minimum 3 screws per bracket.

### Formula for calculating outside drawer width

For drawer side thickness	16 (5/8")	15 (19/32")	14 (9/16")	13 (1/2")	12 (15/32")
Deduct from inside cabinet width	10 (3/8")	12 (15/32")	14 (9/16")	16 (5/8")	18 (23/32")

**Example:** For 21" inside cabinet width and a 5/8" thick drawer, 21" minus 3/8" = 20-5/8" drawer width

### Profile mounting specifications

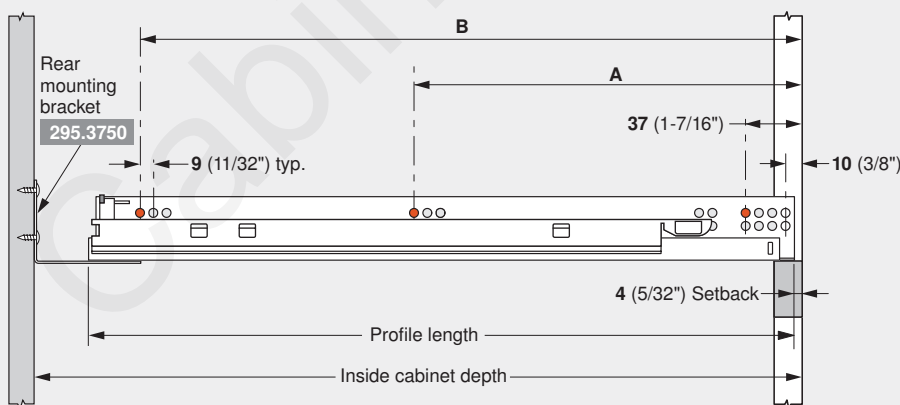

### Profile close-up

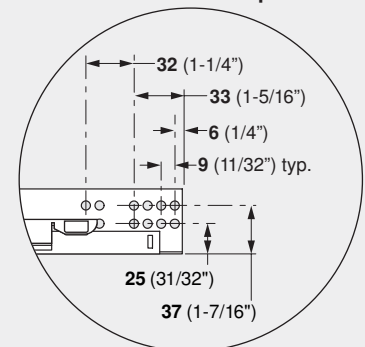

TANDEM plus	TANDEM plus BLUMOTION	Drawer length	Inside cabinet depth with bracket		Profile length	System screw locations	
			Maximum	Minimum		A	B
562H3050C	562H3050B	305 (12")	369 (14-9/16")	326 (12-7/8")	317 (12-1/2")	165 (6-1/2")	261 (10-1/4")
562H3810C	562H3810B	381 (15")	446 (17-9/16")	403 (15-7/8")	394 (15-1/2")	165 (6-1/2")	357 (14-1/16")
562H4570C	562H4570B	457 (18")	522 (20-9/16")	479 (18-7/8")	470 (18-1/2")	261 (10-1/4")	453 (17-13/16")
562H5330C	562H5330B	533 (21")	598 (23-9/16")	555 (21-7/8")	546 (21-1/2")	261 (10-1/4")	517 (20-3/8")