

# 950 SSL Rollout Slide System

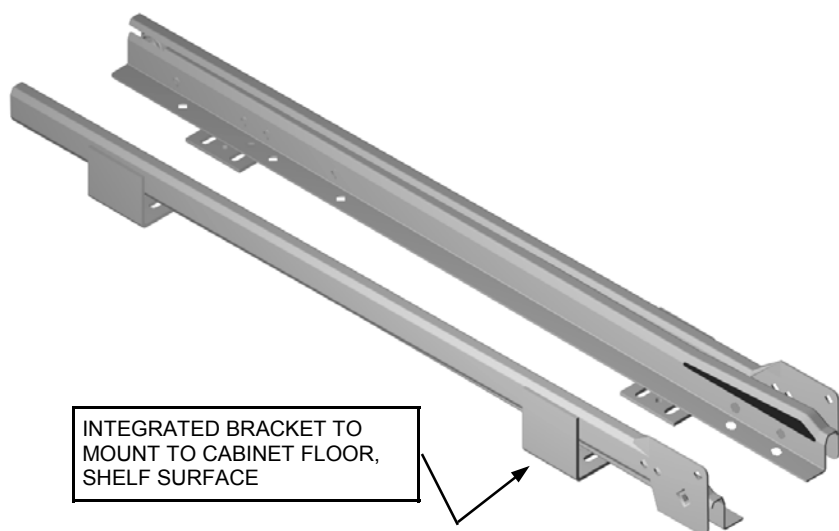

INTEGRATED BRACKET TO MOUNT TO CABINET FLOOR, SHELF SURFACE

## SPECIFICATIONS:

**Material:** Cold Rolled Steel  
**Colors:** White, Almond  
**Capacity:** 100 lbs loading  
**Fastening:** Side or Bottom  
**Packaging:** 20 Pack, 100 Bulk  
**Custom Lengths:** 100 set minimum\*  
 \*Setup charges apply to custom length orders less than 100 sets

## FEATURES:

- Quattro captured for accurate tracking
- Roll formed for smooth, quiet roll
- Patented self-adjusting wheels for mounting tolerances
- Integrated welded brackets
- Standard hole and slot for correctly positioning the slide for installation

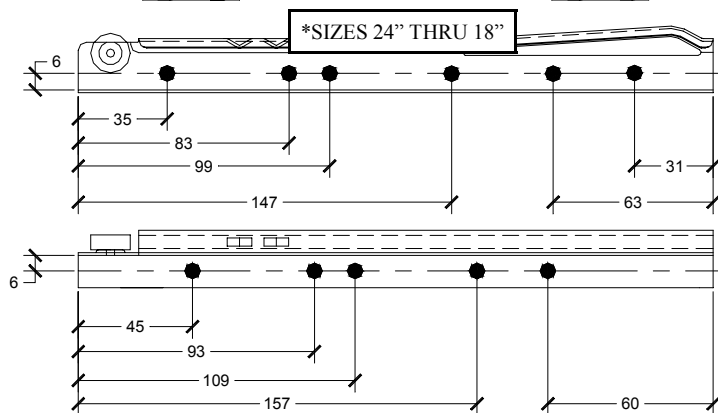
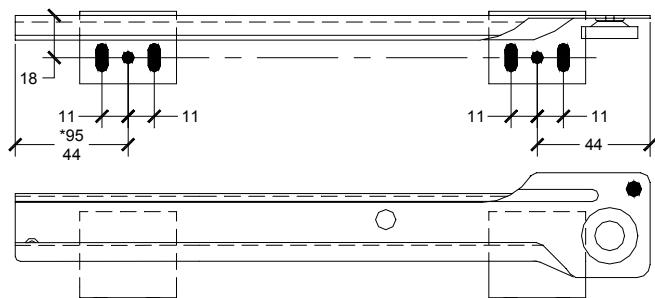

MOUNTING DETAILS

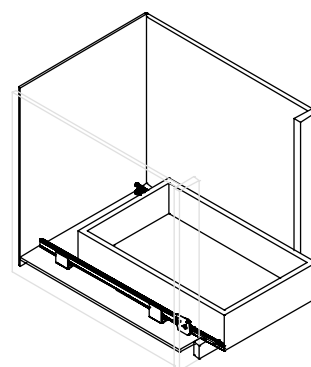

SLIDES IN ROLL-OUT CABINET

ITEM#	SIZE
950SSL600	24" - DT600mm x CT600mm
950SSL550	22" - DT550mm x CT550mm
950SSL500	20" - DT500mm x CT500mm
950SSL450	18" - DT450mm x CT450mm
950SSL400	16" - DT400mm x CT400mm
950SSL350	14" - DT350mm x CT350mm
950SSL300	12" - DT300mm x CT300mm
950SSL250	10" - DT250mm x CT250mm

Longer lengths available in 200 series, see page 200.01