

# TANDEM plus 562F full extension drawer runners

## Overlay application



## Description

- Full extension concealed drawer runners
- Available with integrated BLUMOTION
- For **19** (3/4") max. drawer side thickness
- Rear tilt adjustment
- Concealed roller carriages with permanently lubricated synthetic rollers create a smooth running action
- Locking devices enable easy drawer insertion and removal
- Force-guided right side and  $\pm 1.5$  (1/16") tolerance-compensating left side
- Dynamic load capacity of 75 lb
- Static load capacity of 100 lb

## Basic components

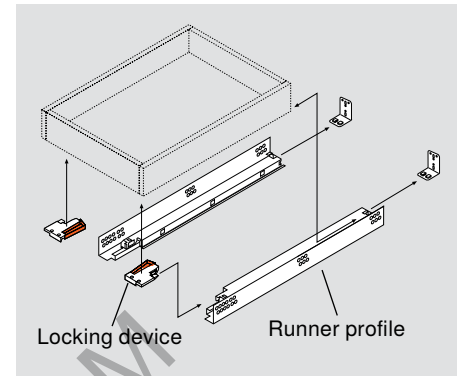

## Other applications



## Components

### Profile set

One set required per drawer

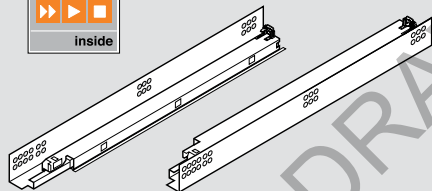

For overall cabinet depth	Drawer length	Over extension	TANDEM plus	TANDEM plus BLUMOTION
305 (12")	229 (9")	—		562F2290B10
381 (15")	305 (12")	—	562F3050C	562F3050B
457 (18")	381 (15")	—	562F3810C	562F3810B
533 (21")	457 (18")	6 (1/4")	562F4570C	562F4570B
610 (24")	533 (21")	16 (5/8")	562F5330C	562F5330B
<b>NOTE:</b> These runners are for <b>19</b> (3/4") maximum drawer side thickness				
Installation screw				707N
Installation screw				661.1300.HG

### Standard locking device

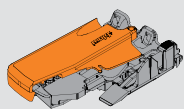

- One right and one left required per drawer
- Minimum interior drawer width **121** (4-3/4")
- Height adjustable **+3** (1/8")

**NOTE:** See page 48 for other options

Part no.

Right locking device **T51.1700.04 R**

Installation Left locking device **T51.1700.04 L**

page 14 Installation screw **612TH**

### Rear mounting bracket for frame cabinets

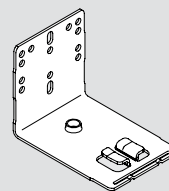

For use when installing TANDEM runners in face frame cabinets. Not necessary for panel cabinet installation.

- Two required per drawer
- Depth and side-to-side self-alignment
- Zinc-coated steel

**NOTE:** See page 50 for 9" TANDEM rear attachment options

Part no.

Non-handed bracket **295.3750.01**

Installation screw **612TH**

Extension	<b>Full</b>
Max. drawer material	<b>19 (3/4")</b>
Dynamic load capacity	<b>75 lb</b>
Static load capacity	<b>100 lb</b>

Drawer and cabinet specifications

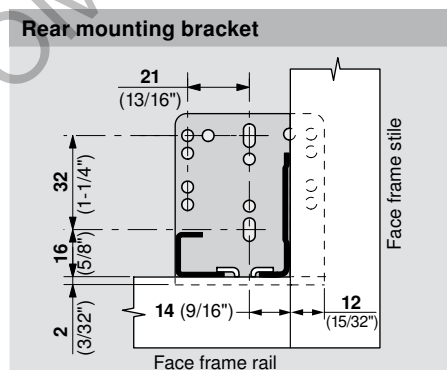
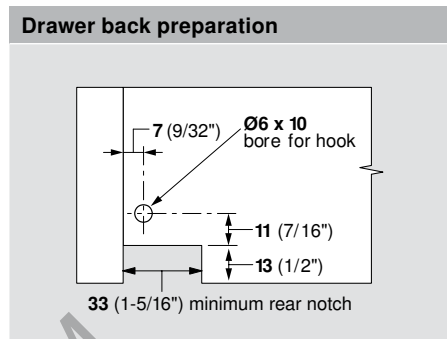
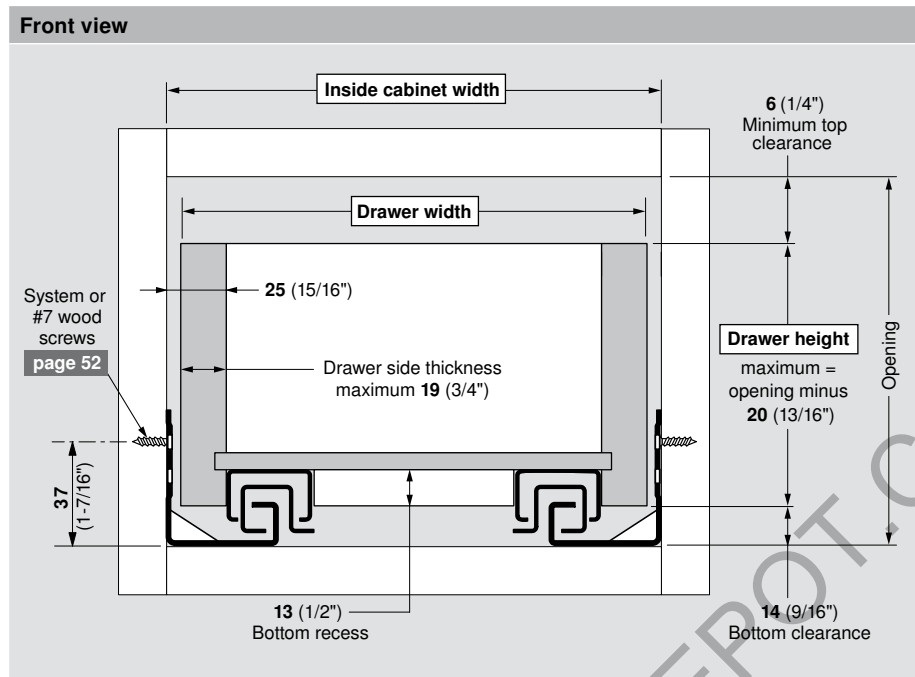

**NOTE:** For frame applications Minimum three screws per bracket

Calculating outside drawer width

For drawer side thickness	19 (3/4")	18 (23/32")	17 (21/32")	16 (5/8")	15 (19/32")
Deduct from inside cabinet width	11 (7/16")	13 (15/32")	14 (9/16")	17 (21/32")	19 (3/4")

**Example:** For 21" inside cabinet width and a 3/4" thick drawer, 21" minus 7/16" = 20-9/16" drawer width

Profile mounting specifications

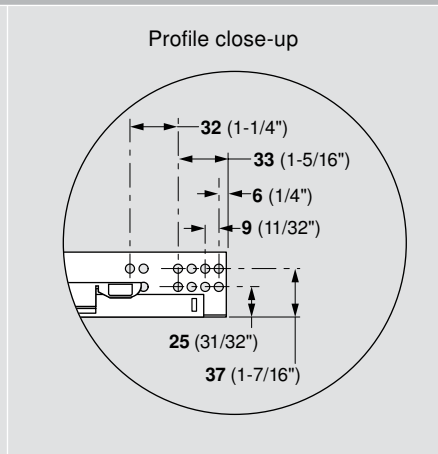
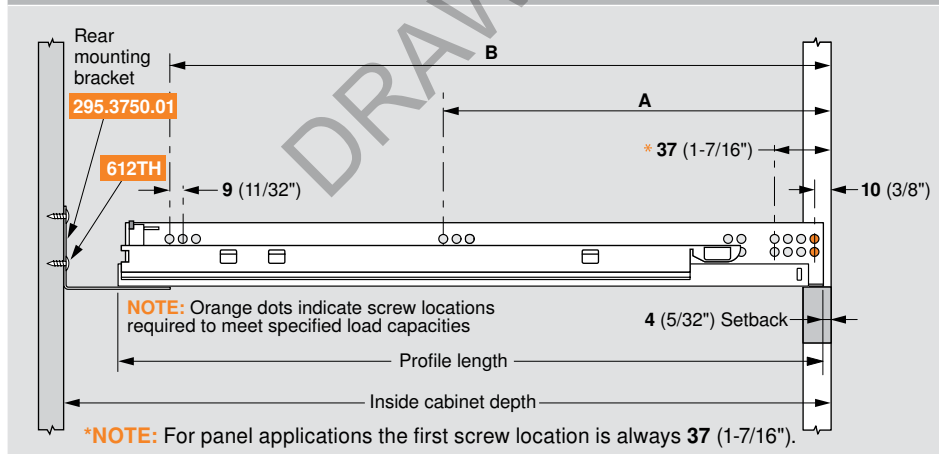

TANDEM plus	TANDEM plus BLUMOTION	Drawer length	Inside cabinet depth with 295.3750.01 bracket		Profile length	Screw locations for panel cabinets	
			Maximum	Minimum		A	B
	562F2290B10	229 (9")	299 (11-3/4")	266 (10-1/2")	262 (105/16")	133 (5-1/2")	229 (9")
562F3050C	562F3050B	305 (12")	369 (14-9/16")	326 (12-7/8")	317 (12-1/2")	165 (6-1/2")	261 (10-1/4")
562F3810C	562F3810B	381 (15")	446 (17-9/16")	403 (15-7/8")	394 (15-1/2")	165 (6-1/2")	357 (14-1/16")
562F4570C	562F4570B	457 (18")	522 (20-9/16")	479 (18-7/8")	470 (18-1/2")	261 (10-1/4")	453 (17-13/16")
562F5330C	562F5330B	533 (21")	598 (23-9/16")	555 (21-7/8")	546 (21-1/2")	261 (10-1/4")	517 (20-3/8")