

Using this section - CLIP top, CLIP and MODUL hinges

Face frame cabinets

Step 1: Determine cabinet construction

Face frame cabinet

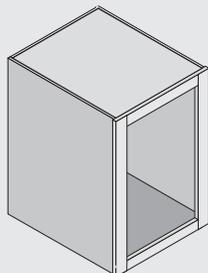

Step 2: Determine the overlay or reveal

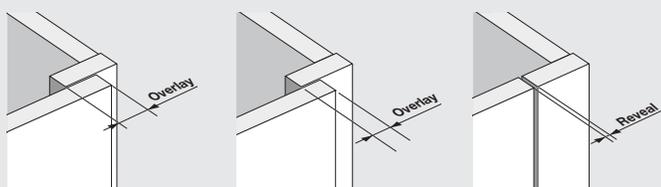

Overlay door Partial Overlay door Inset door

Step 3: Find boring distance and mounting plate height in the table. Example:

Overlay table						
0	14	15	16	17	11.5	20.5
3	11	12	13	14	14.5	23.5
4.5	9.5	10.5	11.5	12.5	16	25
6	8	9	10	11	17.5	26.5
9	5	6	7	8	20.5	29.5
H Plate	3	4	5	6	P Clearance	S

11 fixed distance

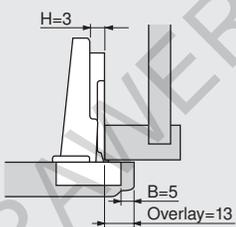

Panel cabinets

Step 1: Determine cabinet construction

Panel cabinet

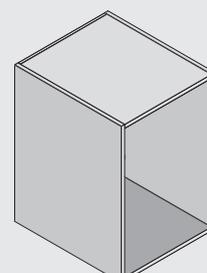

Step 2: Determine the overlay or reveal

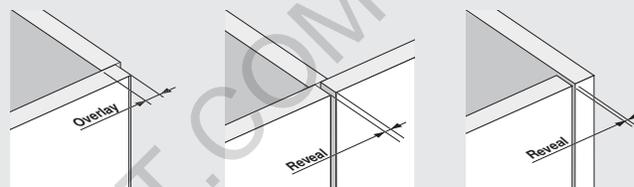

Overlay door Twin doors Inset door

Step 3: Find boring distance and mounting plate height in the table. Example:

Overlay table						
0	14	15	16	17	11.5	20.5
3	11	12	13	14	14.5	23.5
4.5	9.5	10.5	11.5	12.5	16	25
6	8	9	10	11	17.5	26.5
9	5	6	7	8	20.5	29.5
H Plate	3	4	5	6	P Clearance	S

11 fixed distance

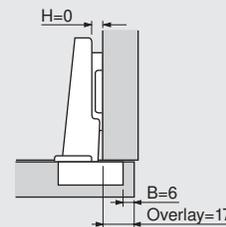

Step 4: Check minimum reveal table

All minimum reveal tables are based on square edge doors with a 1 mm radius. A larger radius or profile door will reduce the minimum reveal. Trial recommended.

Minimum reveal table					
1.2	1.7	2.0	2.4	3.3	3
1.2	1.7	2.0	2.3	3.1	4
1.1	1.6	1.9	2.2	3.0	5
1.1	1.6	1.9	2.2	2.9	6
16	18	19	20	22	B
T Door thickness					Bore

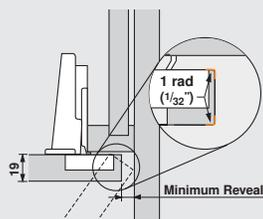

Step 4: Check minimum reveal table

All minimum reveal tables are based on square edge doors with a 1 mm radius. A larger radius or profile door will reduce the minimum reveal. Trial recommended.

Minimum reveal table					
1.2	1.7	2.0	2.4	3.3	3
1.2	1.7	2.0	2.3	3.1	4
1.1	1.6	1.9	2.2	3.0	5
1.1	1.6	1.9	2.2	2.9	6
16	18	19	20	22	B
T Door thickness					Bore

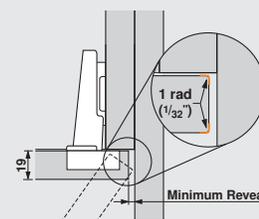

Step 5: Select hinge

Straight-arm hinges

	Self close	Free swing
Screw-on	71T5550	70T5550
Press-in	71T5580	70T5580
Expando	71T558E	-
INSERTA	71T5590B	70T5590B

Step 5: Select hinge

Straight-arm hinges

	Self close	Free swing
Screw-on	71T5550	70T5550
Press-in	71T5580	70T5580
Expando	71T558E	-
INSERTA	71T5590B	70T5590B



CLIP top 120° hinges



Features

- 120° opening angle
- 3-dimensional adjustment
- All metal hinge, nickel plated
- Available with INSERTA tool-free attachment

Cover caps
Mounting plates
BLUMOTION for doors

page 28
pages 45-49
page 73

Minimum Reveal

Minimum reveal table					
1.2	1.7	2.0	2.4	3.3	3
1.2	1.7	2.0	2.3	3.1	4
1.1	1.6	1.9	2.2	3.0	5
1.1	1.6	1.9	2.2	2.9	6
16	18	19	20	22	B
T Door thickness					B Bore

Cross-reference the door thickness and bore distance to assure that doors won't bind when opened.

For door thickness greater than 22mm trial application recommended or use Thick door hinge (page 16).

Step 1

Frame cabinet applications

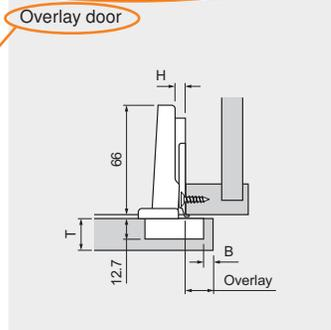

Step 2

Panel cabinet applications

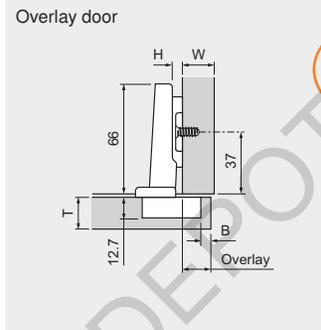

See back cover fold out for more specifications →

Straight-arm hinges

	Self close	Free swing
Screw-on	71T5550	70T5550
Press-in	71T5580	70T5580
Expando	71T558E	-
INSERTA	71T5590B	70T5590B

Overlay table

	0	14	15	16	17	11.5	20.5
3	11	12	13	14	14.5	23.5	
4.5	9.5	10.5	11.5	12.5	16	25	
6	8	9	10	11	17.5	26.5	
9	5	6	7	8	20.5	29.5	
H Plate	3	4	5	6	P	S	
B Bore distance							

Note: 4.5 plate only available for face frame, 9 plate only available for panel cabinets

Step 4

Step 5

Step 3

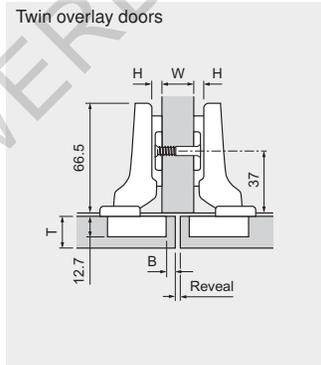
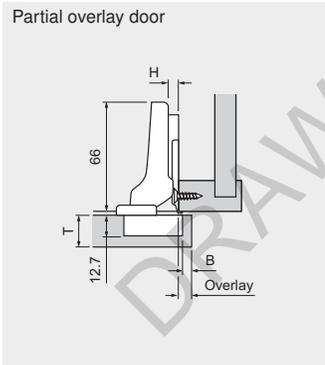

Half-cranked hinges (9.5mm)

	Self close	Free swing
Screw-on	71T5650	70T5650
Press-in	71T5680	70T5680
INSERTA	71T5690B	70T5690B

Overlay table

	0	4.5	5.5	6.5	7.5	21.5	30
H Plate	3	4	5	6	P	S	
B Bore distance							

1.5 fixed distance

Reveal table

	7	5	3	1	16		
0	10	8	6	4	19	21.5	30
	13	11	9	7	22		
H Plate	3	4	5	6	W	P	S
B Bore distance							

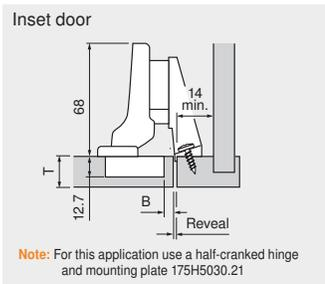

Note: For this application use a half-cranked hinge and mounting plate 175H5030.21

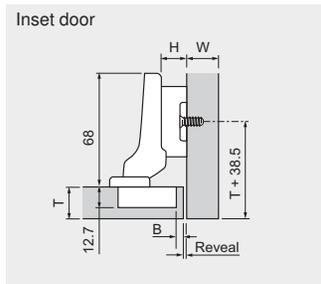

Half-cranked hinges (9.5mm)

	Self close	Free swing
Screw-on	71T5650	70T5650
Press-in	71T5680	70T5680
INSERTA	71T5690B	70T5690B

Reveal table

	9	4.5	3.5	2.5	1.5	30.5	39
H Plate	3	4	5	6	P	S	
B Bore distance							

-7.5 fixed distance

Ram needed for use with MINIPRESS

For more information on using this section see page 5.
All dimensions in millimeters.
Subject to technical modifications without notice. © 2006

