



Concealed hinges

Function and design for perfect motion



Beautiful hinges inside and out



Blum, Inc. is a leading manufacturer of functional hardware for the kitchen cabinet and commercial casegoods industries specializing in concealed hinges, drawer runner systems and lift systems. Virtually all of the hardware needed to assemble and make cabinets functional are available within the wide range of quality Blum products.

Blum's manufacturing and distribution facility in Stanley, North Carolina supplies the North American markets through a network of more than 150 dependable distributors. Wholly owned by the Blum family, the company was formed in 1952 by Julius Blum and is headquartered in Hoechst, Austria.

Global customer benefits

Product development at Blum considers all of the various customers who will come in contact with our products.



With this "Global Customer Benefits" philosophy we strive to create advantages for all users from the manufacturer to the end consumer.

Blum, Inc. is ISO 9001 certified which means that you are assured of consistent quality in every Blum product. What's more they exceed the requirements of ANSI-BHMA standards for cycle life, static load and self-closing performance. Contact your local Blum representative for more details.



CLIP and CLIP top hinge series



- Audible "CLIP" sound confirms the secure connection between hinge and plate
- INSERTA Tool-free attachment and removal
- Mounting plates for panel and face frame
- Nickel plated steel construction
- 3-dimensional adjustments for precise door alignment
- Hinges for angled solutions

CLIP top – Blum's top-of-the-line hinge with the exclusive Spiral-Tech depth adjustment

CLIP – The industry standard for tool-free attachment since 1985

MODUL hinge series



- Simple slide on attachment
- Economical solution
- Mounting plates for panel and face frame
- Nickel plated steel construction
- 3-dimensional adjustment for precise door alignment
- Functional and long lasting

COMPACT hinge series



- Small profile for face frame cabinets
- 38/39 series
 - Nickel plated steel construction
 - 38N and 38/39C: 3-dimensional adjustment
 - 38A: 2-dimensional adjustment
 - 38.: height adjustment
- 33 series
 - Nickel plated zinc die cast construction
 - 2-dimensional adjustment
 - Wide variety of small and large overlays

Table of contents

CLIP top and CLIP hinges

Program overview	page 3	CLIP top hinges	pages 11-23
Using this section	pages 4-6	CLIP hinges	pages 28-30
General specifications	pages 9-10	Cover caps & angle restriction clips	page 31

CLIP top/CLIP

CLIP top angled hinges

Program overview	pages 33-34	Specifications	pages 38-44
Angled cabinet configurations	pages 35-36		
Angle-to-style cross-reference	page 37		

Angled

CLIP mounting plates

Mounting plates	pages 47-50		
Face frame adapter plates	pages 50-51		

CLIP plates

MODUL hinges and mounting plates

Using this section	pages 4-6	Mounting plates	pages 57-58
General specifications	page 53	Cover caps	page 59
Hinges	pages 54-55		

MODUL

COMPACT hinges

Program Overview	pages 62	Hinges	pages 66-71
Using this section	pages 63-64	Cover caps	page 72
General specifications	page 65		

COMPACT

Machines and assembly aids

Templates and accessories	pages 74-78	MINIPRESS / MINIDRILL accessories	page 83 - 84
Screws, bumpers, dowels and POZI driver	pages 79-80	Knock-in tool & drill bits	page 85
MINIPRESS / MINIDRILL	pages 81-82	Blum testing standards	page 86

Assembly aids



Program overview - Euro hinges

	CLIP top		CLIP		MODUL	
100° hinge						
				page 28		page 54
107° hinge						
				page 29		
120° hinge						
		120° page 12				
		120°+ page 13				page 55
170° hinge						
		170° page 14				
		Special page 15		page 30		
110° hinge						
						page 16
95° Thick door hinge						
						page 18
Zero protrusion hinge						
						page 19
Aluminum door hinge						
						BMN page 20
						120° page 21
Blind corner hinge						
						Inset page 22
						Overlay page 24
Diagonal 45° hinge						
						page 23
Mini hinge						
						page 25
Glass door hinge						
						page 26
Bi-fold hinge						
						page 27
Angled hinges						
						page 33
Mounting plates						
						page 47
						page 47
						page 57



Using this section

Blum's Euro hinge page format

Blum's concealed hinge brochure makes it easy to use our Euro hinges. Each page shows information for both face frame and frameless (panel) applications. The left column shows the hinge in a face frame cabinet and the center column shows it in a panel cabinet. The right column holds the overlay and reveal tables.

Blum makes it easy to use CLIP top, CLIP and MODUL no matter which type of cabinet you build.

Frame cabinet construction

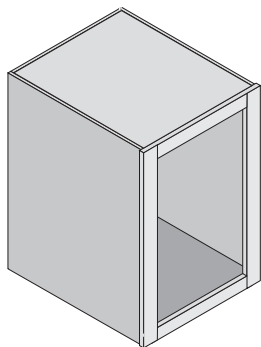

To use Euro hinges in a face frame cabinet use the left column.

Frameless (panel) cabinet construction

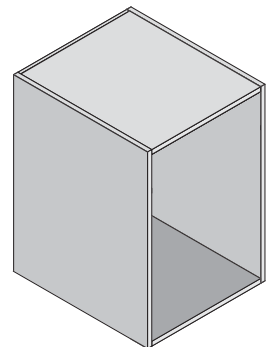

To use Euro hinges in a frameless cabinet use the center column.

CLIP top 120° hinges

Features

- 120° opening angle
- 3-dimensional adjustment
- All metal hinge, nickel plated
- Available with INSERTA tool-free attachment

Cover caps page 31
Mounting plates pages 47-52

Minimum Reveal

1.2	1.7	2.0	2.4	3.3	3
1.2	1.7	2.0	2.3	3.1	4
1.1	1.6	1.9	2.2	3.0	5
1.1	1.6	1.9	2.2	2.9	6
1.6	1.8	1.9	2.2	2.8	8
T: Door thickness					

Cross-reference the door thickness and bore distance to assure that doors won't bind when opened.

For door thickness greater than 22mm final application recommended or use Thick door hinge (page 18).

CLIP top/CLIP

120°

Frame cabinet applications

Overlay door

Partial overlay door

Inset door

NOTE: For this application use a half-cranked hinge and mounting plate 179H500.21

Panel cabinet applications

Overlay door

Twin overlay doors

Inset door

See back cover fold out for more specifications →

Straight-arm hinges

Self close	Free swing
Screw-on	7115550 7015550
Press-in	7115550 7015550
Expando	711555E
INSERTA	7115590B 7015590B

Overlay table

0	4	14	16	17	11.5	20.5
3	11	12	13	14	14.5	23.5
4.5	9.5	10.5	11.5	12.5	16	25
6	8	9	10	11	17.5	26.5
9	5	6	7	8	20.5	29.5
H	3	4	5	6	P	S
Plate	B	Bore distance	Clearance			

11 fixed distance

Half-cranked hinges (9.5mm)

Self close	Free swing
Screw-on	7115650 7015650
Press-in	7115650 7015650
INSERTA	7115690B 7015690B

Overlay table

0	4.5	5.5	6.5	7.5	21.5	30
H	3	4	5	6	P	S
Plate	B	Bore distance	Clearance			

15 fixed distance

Half-cranked hinges (9.5mm)

Self close	Free swing
Screw-on	7115650 7015650
Press-in	7115650 7015650
INSERTA	7115690B 7015690B

Reveal table

9	4.5	3.5	2.5	1.5	30.5	39
H	3	4	5	6	P	S
Plate	B	Bore distance	Clearance			

15 fixed distance

blum

Cross-reference tables

The right column holds the Overlay, Reveal and Minimum Reveal tables. It also contains the part numbers of the hinges for each application. These charts are explained, step-by-step, on the next two pages.

Using this section - CLIP top, CLIP and MODUL hinges

Face frame cabinets

Step 1: Determine cabinet construction

Face frame cabinet

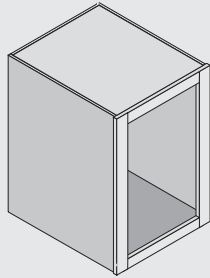

Step 2: Determine the overlay or reveal

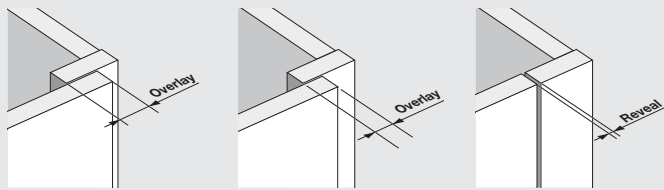

Overlay door

Partial Overlay door

Inset door

Step 3: Find boring distance and mounting plate height in the table. Example:

Overlay table						
0	14	15	16	17	11.5	20.5
3	11	12	13	14	14.5	23.5
4.5	9.5	10.5	11.5	12.5	16	25
6	8	9	10	11	17.5	26.5
9	5	6	7	8	20.5	29.5
H Plate	3	4	5	6	P Clearance	S

11 fixed distance

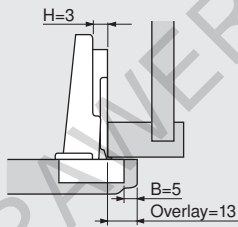

Panel cabinets

Step 1: Determine cabinet construction

Panel cabinet

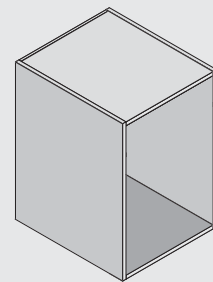

Step 2: Determine the overlay or reveal

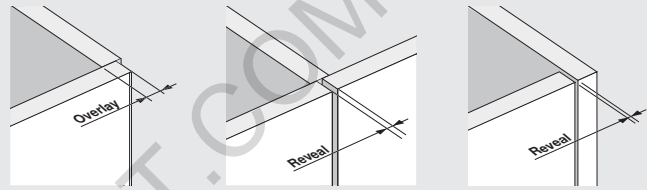

Overlay door

Twin doors

Inset door

Step 3: Find boring distance and mounting plate height in the table. Example:

Overlay table						
0	14	15	16	17	11.5	20.5
3	11	12	13	14	14.5	23.5
4.5	9.5	10.5	11.5	12.5	16	25
6	8	9	10	11	17.5	26.5
9	5	6	7	8	20.5	29.5
H Plate	3	4	5	6	P Clearance	S

11 fixed distance

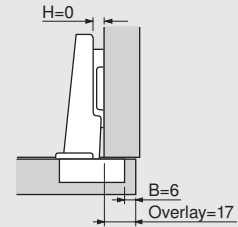

Step 4: Check minimum reveal table

All minimum reveal tables are based on square edge doors with a 1 mm radius. A larger radius or profile door will reduce the minimum reveal. Trial recommended.

Minimum reveal table					
1.2	1.7	2.0	2.4	3.3	3
1.2	1.7	2.0	2.3	3.1	4
1.1	1.6	1.9	2.2	3.0	5
1.1	1.6	1.9	2.2	2.9	6
16	18	19	20	22	B

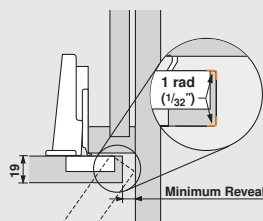

Step 4: Check minimum reveal table

All minimum reveal tables are based on square edge doors with a 1 mm radius. A larger radius or profile door will reduce the minimum reveal. Trial recommended.

Minimum reveal table					
1.2	1.7	2.0	2.4	3.3	3
1.2	1.7	2.0	2.3	3.1	4
1.1	1.6	1.9	2.2	3.0	5
1.1	1.6	1.9	2.2	2.9	6
16	18	19	20	22	B

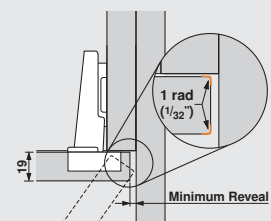

Step 5: Select hinge

Straight-arm hinges

	Self close	Free swing
Screw-on	71T5550	70T5550
Press-in	71T5580	70T5580
Expando	71T558E	-
INSERTA	71T5590B	70T5590B

Step 5: Select hinge

Straight-arm hinges

	Self close	Free swing
Screw-on	71T5550	70T5550
Press-in	71T5580	70T5580
Expando	71T558E	-
INSERTA	71T5590B	70T5590B



CLIP top 120° hinges

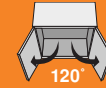

Features

- 120° opening angle
- 3-dimensional adjustment
- All metal hinge, nickel plated
- Available with INSERTA tool-free attachment

Cover caps
Mounting plates
BLUMOTION for doors

page 28
pages 45-49
page 73

Minimum Reveal

Minimum reveal table					
1.2	1.7	2.0	2.4	3.3	3
1.2	1.7	2.0	2.3	3.1	4
1.1	1.6	1.9	2.2	3.0	5
1.1	1.6	1.9	2.2	2.9	6
16	18	19	20	22	B
T Door thickness					B Bore

Cross-reference the door thickness and bore distance to assure that doors won't bind when opened.

For door thickness greater than 22mm trial application recommended or use Thick door hinge (page 16).

Step 1

Frame cabinet applications

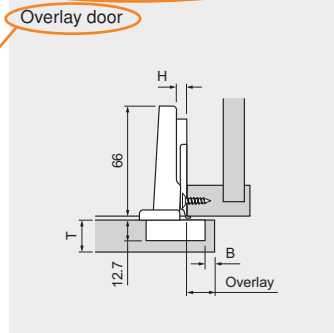

Step 2

Panel cabinet applications

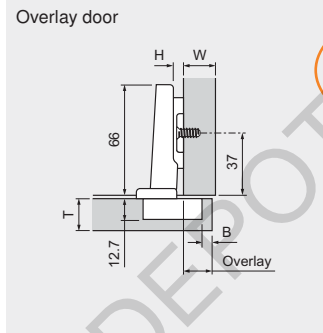

See back cover fold out for more specifications →

Straight-arm hinges

	Self close	Free swing
Screw-on	71T5550	70T5550
Press-in	71T5580	70T5580
Expando	71T558E	-
INSERTA	71T5590B	70T5590B

Overlay table

	0	14	15	16	17	11.5	20.5
3	11	12	13	14	14.5	23.5	
4.5	9.5	10.5	11.5	12.5	16	25	
6	8	9	10	11	17.5	26.5	
9	5	6	7	8	20.5	29.5	
H Plate	3	4	5	6	P	S	
B Bore distance							11 fixed distance

Note: 4.5 plate only available for face frame, 9 plate only available for panel cabinets

Step 4

Step 5

Step 3

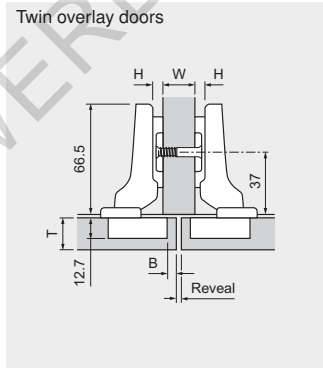
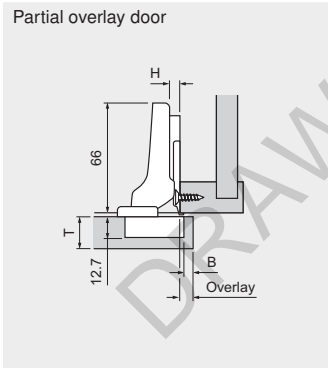

Half-cranked hinges (9.5mm)

	Self close	Free swing
Screw-on	71T5650	70T5650
Press-in	71T5680	70T5680
INSERTA	71T5690B	70T5690B

Overlay table

	0	4.5	5.5	6.5	7.5	21.5	30
H Plate	3	4	5	6	P	S	
B Bore distance							Clearances

1.5 fixed distance

Reveal table

	7	5	3	1	16		
0	10	8	6	4	19	21.5	30
	13	11	9	7	22		
H Plate	3	4	5	6	W	P	S
B Bore distance							Clearances

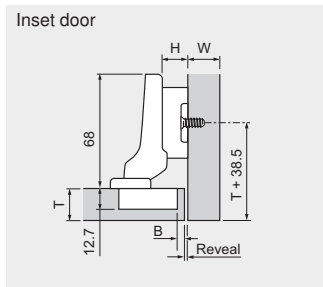
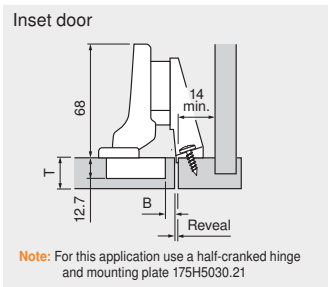

Half-cranked hinges (9.5mm)

	Self close	Free swing
Screw-on	71T5650	70T5650
Press-in	71T5680	70T5680
INSERTA	71T5690B	70T5690B

Reveal table

	9	4.5	3.5	2.5	1.5	30.5	39
H Plate	3	4	5	6	P	S	
B Bore distance							Clearances

-7.5 fixed distance

Ram needed for use with MINIPRESS

For more information on using this section see page 5.
All dimensions in millimeters.
Subject to technical modifications without notice. © 2006



DRAWERDEPOT.COM



CLIP top and CLIP hinges



CLIP top and CLIP hinges

CLIP top/CLIP

INSERTA tool-free assembly

Blum offers tool-free attachment of hinge to door and plate to cabinet with its INSERTA hinges and mounting plates.



Time proven CLIP technology

Since 1985, the CLIP hinge has been an industry leader in easy, tool-free attachment of door to cabinet.



BLUMOTION silent closing

Blum hinges are made to work with optional BLUMOTION silent closing devices for a controlled close, every time.



Spiral-Tech depth adjustment

With Blum's Spiral-Tech depth adjustment, just one and three quarter revolutions of the screw creates 5 mm of adjustment without loosening and retightening a fixing screw.

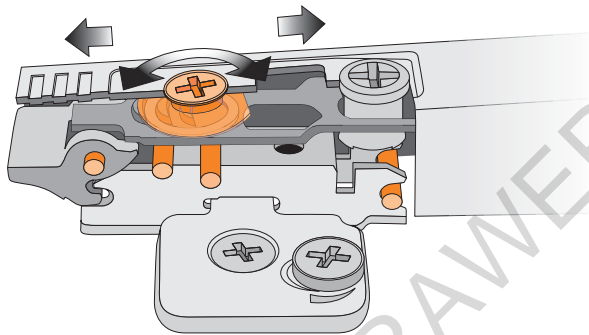

Side adjustment

Blum's side adjustment is a flush screwhead that allows 4 mm of adjustment. It also has an integral stop that prevents removal.

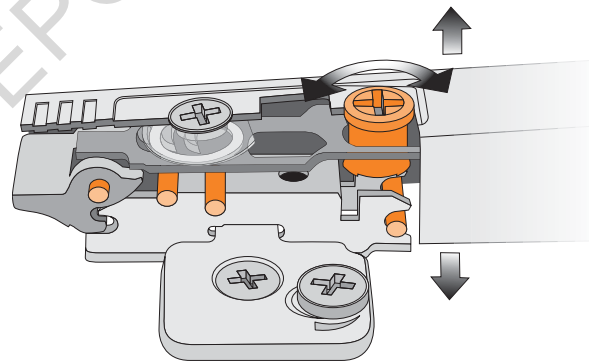

Blum three-point contact

CLIP top and CLIP hinges have three-point contact between the hinge and mounting plate to keep them firmly connected under heavy usage.

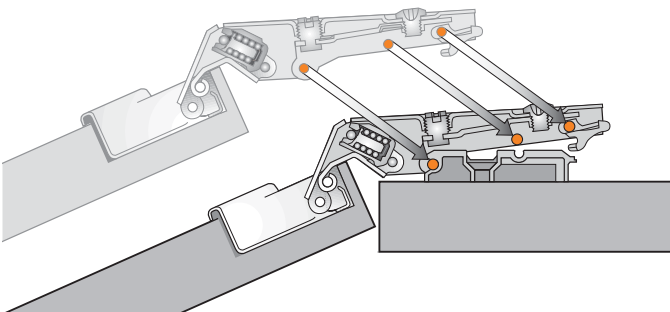

Wide variety of mounting plates

Blum has mounting plates for every application, from wing plates with pre-attached screws or dowels, to Cam height adjustable face frame adapters, to sleek in-line mounting plates.





General specifications

Hinge-to-door attachment

Screw-on Use #6 wood screws	Press-in Pre-attached dowels installed with Blum MINIPRESS	EXPANDO Pre-attached expanding dowels	INSERTA Tool-free attachment (cup expands into Ø35 mm hole)
---	--	---	---

CLIP top/CLIP

Hinge cup centerpoint

C Cup centerpoint					
20.5	21.5	22.5	23.5	24.5	25.5
13/16"	27/32"	7/8"	15/16"	31/32"	1"
3	4	5	6	7*	8*

B Bore distance
* only for use with select Blum hinges

Cup centerpoint is the MINIPRESS or MINIDRILL fence depth position.

Mounting plate-to-cabinet

 Screw-on	 EXPANDO	 INSERTA
--------------	-------------	-------------

Three-dimensional adjustment

<p>Side adjustment</p> <p>Turn front screw to increase or decrease door overlay (± 2 mm).</p>	<p>Height adjustment</p> <p>Rotate cam screw-on mounting plate to adjust door position (± 2 mm).</p> <p>On non-cam mounting plates, loosen screw, adjust door and retighten screws.</p>	<p>Depth adjustment</p> <p>Turn rear spiral-tech cam screw to adjust door position (+3 mm, -2 mm).</p> <p>For CLIP, loosen rear screw, adjust and retighten.</p>
---	---	---

Hinge dimension abbreviations

- B = Boring distance
- H = Mounting plate height
- OL = Door overlay
- P = Door protrusion (at max opening)
- R = Reveal
- S = Hinge arm protrusion
- T = Door thickness
- W = Side panel width
- X = Fixed distance

Hinges per door

Door Height (X)	Number of Hinges (Y)	Weight Range
20"	2	15 lb.
40"	3	15-30 lb.
60"	4	30-45 lb.
80"	5	45-60 lb.

This chart can serve as a guide for determining the number of hinges per door. Note that door weight can also determine the number of hinges required.

Important: The distance between the top and bottom hinges must be greater than the width of the door.

X = Door height
Y = Number of hinges

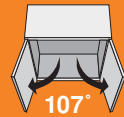

CLIP top 107° hinges

CLIP top/CLIP



Features

- 107° opening angle
- Three-dimensional adjustment
- All metal hinge, nickel plated
- Available with INSERTA tool-free attachment
- 86° angle restriction clips available (page 31)

Cover caps
Mounting plates

page 31
pages 47-52

Minimum Reveal

Minimum reveal table						
0.6	1.0	1.3	1.7	2.5	3	
0.6	1.0	1.3	1.6	2.4	4	
0.6	1.0	1.2	1.5	2.2	5	
0.6	1.0	1.2	1.4	2.0	6	
16	18	19	20	22	B	
T Door thickness					Bore	

Cross-reference the door thickness and bore distance to assure that doors won't bind when opened.

For door thickness greater than 22 mm trial application recommended or use Thick door hinge (page 18).

Frame cabinet applications

Overlay door

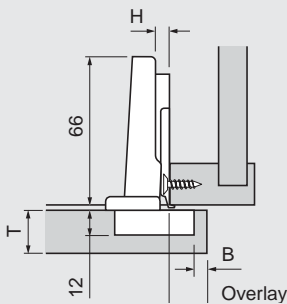

Panel cabinet applications

Overlay door

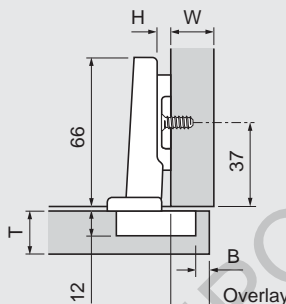

See back cover fold out for more specifications →

Straight-arm hinges

	Self close	Free swing
Screw-on	75T1550	74T1550.TL
Press-in	75T1580	74T1580.TL
INSERTA	75T1590B	74T1590BTL

Overlay table

0	14	15	16	17	10	21
3	11	12	13	14	13	24
4.5	9.5	10.5	11.5	12.5	14.5	25.5
6	8	9	10	11	16	27
9	5	6	7	8	19	30
H	3	4	5	6	P	S
Plate	B Bore distance				Clearances	

11 fixed distance

NOTE: 4.5 plate only available for face frame, 9 plate only available for panel cabinets

Half-cranked hinges (9.5 mm)

	Self close
Screw-on	75T1650
Press-in	75T1680
INSERTA	75T1690B

Overlay table

Overlay table						Partial overlay	
0	4.5	5.5	6.5	7.5	20	31	
H	3	4	5	6	P	S	
Plate	B Bore distance				Clearances		

1.5 fixed distance

Reveal table

Reveal table							Twin overlay	
0	7	5	3	1	16	20	31	
	10	8	6	4	19			
	13	11	9	7	22			
H	3	4	5	6	W	P	S	
Plate	B Bore distance				Panel	Clearances		

Full-cranked hinges (18 mm)

	Self close
Screw-on	75T1750
Press-in	75T1780
INSERTA	75T1790B

Reveal table

0	4	3	2	1	29	40
H	3	4	5	6	P	S
Plate	B Bore distance				Clearances	

- 7 fixed distance

Partial overlay door

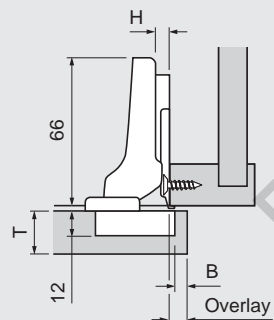

Twin overlay doors

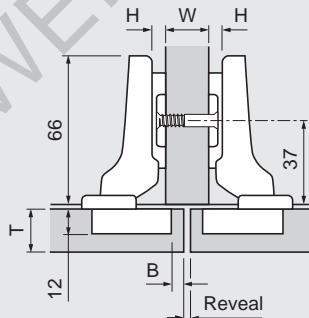

Inset door

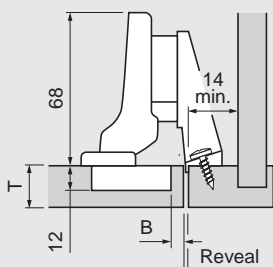

NOTE: For this application use a half-cranked hinge from above and mounting plate 175H5030.21

Inset door

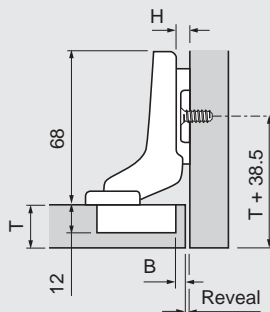

CLIP top 120° hinges

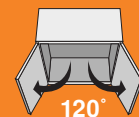

Features

- 120° opening angle
- Three-dimensional adjustment
- All metal hinge, nickel plated
- Available with INSERTA tool-free attachment

Cover caps
Mounting plates

page 31
pages 47-52

Minimum Reveal

Minimum reveal table					
1.2	1.7	2.0	2.4	3.3	3
1.2	1.7	2.0	2.3	3.1	4
1.1	1.6	1.9	2.2	3.0	5
1.1	1.6	1.9	2.2	2.9	6
16	18	19	20	22	B
T Door thickness					Bore

Cross-reference the door thickness and bore distance to assure that doors won't bind when opened.

For door thickness greater than 22 mm trial application recommended or use Thick door hinge (page 18).

Frame cabinet applications

Overlay door

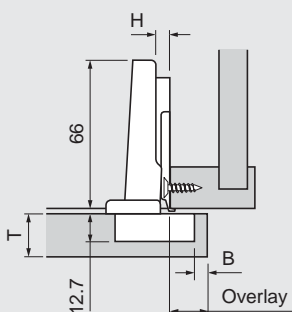

Panel cabinet applications

Overlay door

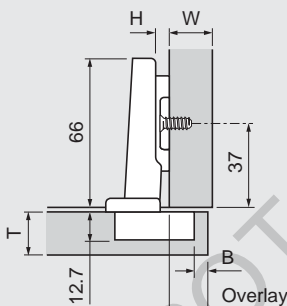

See back cover fold out for more specifications →

Straight-arm hinges

	Self close	Free swing
Screw-on	71T5550	70T5550.TL
Press-in	71T5580	70T5580.TL
Expando	71T558E	-
INSERTA	71T5590B	70T5590BTL

Overlay table					
0	14	15	16	17	11.5 20.5
3	11	12	13	14	14.5 23.5
4.5	9.5	10.5	11.5	12.5	16 25
6	8	9	10	11	17.5 26.5
9	5	6	7	8	20.5 29.5
H	3	4	5	6	P S
Plate	B Bore distance				Clearance

NOTE:
4.5 plate only available for face frame, 9 plate only available for panel cabinets

11 fixed distance

Partial overlay door

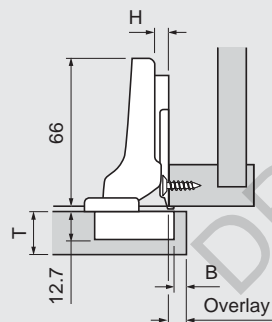

Twin overlay doors

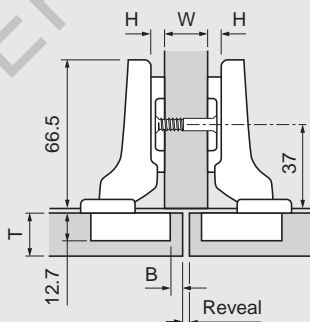

Half-cranked hinges (9.5 mm)

	Self close	Free swing
Screw-on	71T5650	70T5650.TL
Press-in	71T5680	70T5680.TL
INSERTA	71T5690B	70T5690BTL

Overlay table					
0	4.5	5.5	6.5	7.5	21.5 30
H	3	4	5	6	P S
Plate	B Bore distance				Clearances

1.5 fixed distance

Reveal table					
0	7	5	3	1	16
	10	8	6	4	19
	13	11	9	7	22
H	3	4	5	6	W
Plate	B Bore distance				Clearances

Inset door

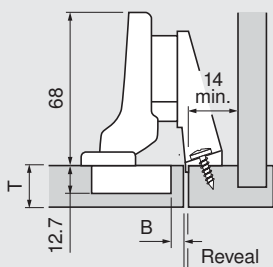

NOTE: For this application use a half-cranked hinge and mounting plate 175H5030.21

Inset door

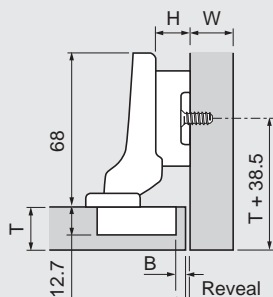

Half-cranked hinges (9.5 mm)

	Self close	Free swing
Screw-on	71T5650	70T5650.TL
Press-in	71T5680	70T5680.TL
INSERTA	71T5690B	70T5690BTL

Reveal table					
9	4.5	3.5	2.5	1.5	30.5 39
H	3	4	5	6	P S
Plate	B Bore distance				Clearances

-7.5 fixed distance

For more information on using this section see page 5.

All dimensions in millimeters.

Subject to technical modifications without notice. © 2008

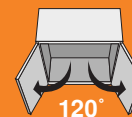

CLIP top 120°+ hinges

CLIP top/CLIP



Features

- 120° opening angle
- For larger overlays (max. 21 mm)
- Three-dimensional adjustment
- All metal hinge, nickel plated
- Available with INSERTA tool-free attachment

Cover caps
Mounting plates

page 31
pages 47-52

Minimum Reveal

Minimum reveal table						
1.2	1.7	2.0	2.4	3.3	3	
1.2	1.7	2.0	2.3	3.1	4	
1.1	1.6	1.9	2.2	3.0	5	
1.1	1.6	1.9	2.2	2.9	6	
16	18	19	20	22	B	
T Door thickness					Bore	

Cross-reference the door thickness and bore distance to assure that doors won't bind when opened.

For door thickness greater than 22 mm trial application recommended or use Thick door hinge (page 18).

Frame cabinet applications

Overlay door

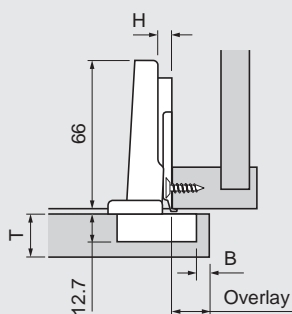

Panel cabinet applications

Overlay door

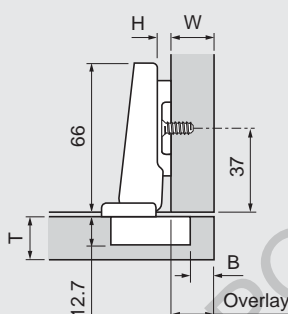

See back cover fold out for more specifications →

Straight-arm hinges

	Self close	Free swing
Screw-on	73T5550	72T5550.TL
Press-in	73T5580	72T5580.TL
Expando	73T558E	-
INSERTA	73T5590B	72T5590BTL

Overlay table						
0	16	17	18	19	9.5	19
3	13	14	15	16	12.5	22
4.5	11.5	12.5	13.5	14.5	14	23.5
6	10	11	12	13	15.5	25
9	7	8	9	10	18.5	28
H Plate	3	4	5	6	P Bore distance	S Clearance

NOTE:
4.5 plate only available for face frame, 9 plate only available for panel cabinets

13 fixed distance

Straight-arm hinges

	Self close	Free swing
Screw-on	73T5550	72T5550.TL
Press-in	73T5580	72T5580.TL
Expando	73T558E	-
INSERTA	73T5590B	72T5590BTL

Reveal table						Twin overlay	
2	-	-	-	16			
9	5	3	-	19	18.5	28	
	8	6	4	22			
H Plate	3	4	5	6	W	P S	Clearances

4 fixed distance

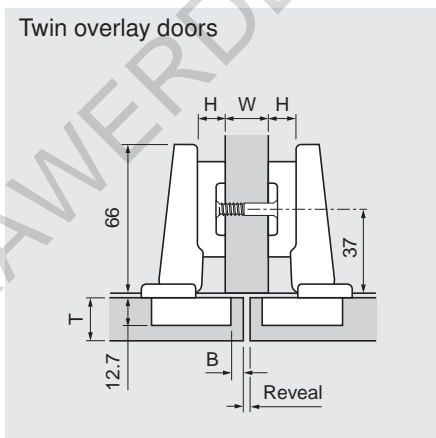
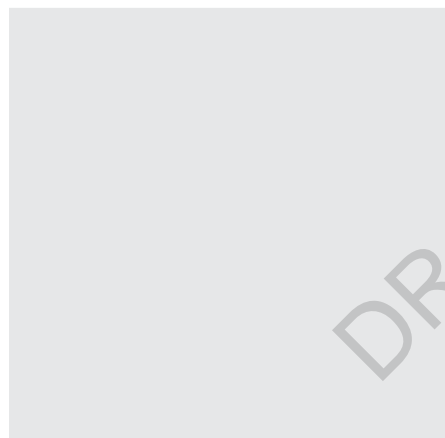

Building both frame and panel cabinets

Frame

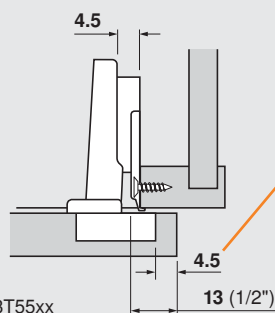

Hinge: 73T55xx
Plate: 175H6040

Panel

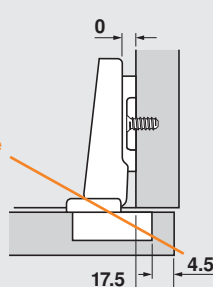

Hinge: 73T55xx
Plate: any 0 plate

Same boring distance

The most common overlays for frame and panel cabinets can be achieved by using the same machine setting for hinge cup boring.

Bore **ALL** doors at 4.5 mm to achieve:
- 13 mm (1/2") overlay on frame cabinets and
- 17.5 mm overlay on panel cabinets

Use hinge/plate combinations to the left.

Advantages:

- Only one machine setting for boring all doors (4.5 mm)
- Same hinge used for both applications (73T55xx)

For more information on using this section see page 5.

All dimensions in millimeters.

Subject to technical modifications without notice. © 2008

CLIP top 170° hinges



Features

- 170° opening angle
- Three-dimensional adjustment
- All metal hinge, nickel plated
- Available with INSERTA tool-free attachment
- 130° angle restriction clips are available (see pages 15 and 31)

Cover caps
Mounting plates

page 31
pages 47-52

Minimum Reveal

Minimum reveal table						
0	0	0	0	0.2	2.2	3
0	0	0	0	0	1.4	4
0	0	0	0	0	0.9	5
0	0	0	0	0	0	6
0	0	0	0	0	0	7
0	0	0	0	0	0	8
16	18	19	20	22	24	B
T Door thickness						Bore

Cross-reference the door thickness and bore distance to assure that doors won't bind when opened.

Frame cabinet applications

Overlay door

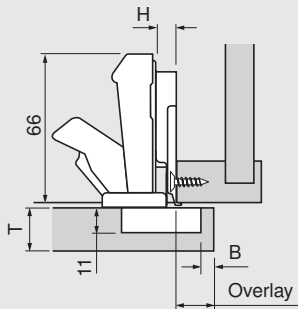

NOTE: 175H6xxx or 175L6600.24 recommended

Panel cabinet applications

Overlay door

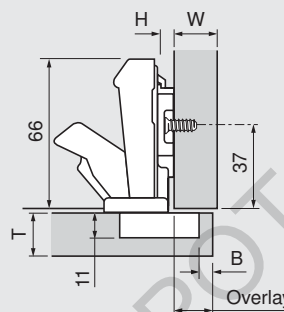

Straight-arm hinges

	Self close	Free swing
Screw-on	71T6550	70T6550
Press-in	71T6580	70T6580
INSERTA	71T6540B	70T6540B

Overlay table								
0	14	15	16	17	18	19	1.5	65
3	11	12	13	14	15	16	4.5	68
4.5	9.5	10.5	11.5	12.5	13.5	14.5	6	69.5
6	8	9	10	11	12	13	7.5	71
9	5	6	7	8	9	10	10.5	74
H Plate	3	4	5	6	7	8	P Clearances	S Clearances

11 fixed distance

NOTE: 4.5 plate only available for face frame, 9 plate only available for panel cabinets

Partial overlay door

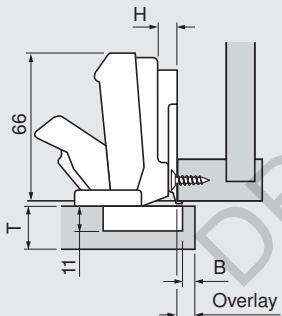

NOTE: 175H6xxx or 175L6600.24 recommended

Twin overlay doors

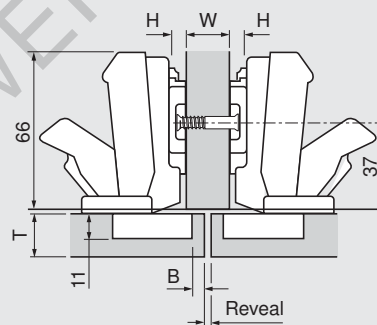

Half-cracked hinges (9.5 mm)

	Self close	Free swing
Screw-on	71T6650	70T6650
Press-in	71T6680	70T6680
INSERTA	71T6640B	-

Overlay table							Partial overlay	
0	4.5	5.5	6.5	7.5	8.5	9.5	11	75
H Plate	3	4	5	6	7	8	P Clearances	S Clearances

1.5 fixed distance

Reveal table							Twin overlay		
0	7	5	3	1	-	-	16	11	75
	10	8	6	4	2	0	19		
	13	11	9	7	5	3	22		
H Plate	3	4	5	6	7	8	W Panel	P Clearances	S Clearances

NOTE: Inset application not possible with 170 hinges and the inset face frame adapter (175H5030.21)

Inset door

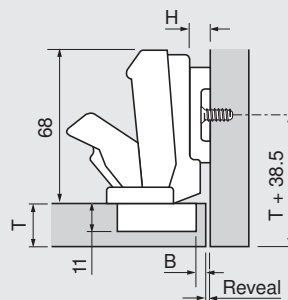

NOTE: See next page for special thick door requirements

Half-cracked hinges (9.5 mm)

	Self close	Free swing
Screw-on	71T6650	70T6650
Press-in	71T6680	70T6680
INSERTA	71T6640B	-

Reveal table								
9	4.5	3.5	2.5	1.5	0.5	-	20	84
H Plate	3	4	5	6	7	8	P Clearances	S Clearances

- 7.5 fixed distance



CLIP top 170° special applications

CLIP top/CLIP

Applications

Thick door application

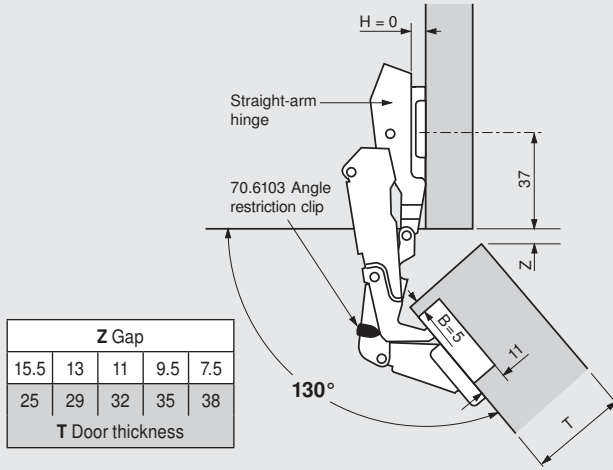

Z Gap				
15.5	13	11	9.5	7.5
25	29	32	35	38
T Door thickness				

Note: Be aware of door weight, see page 10 for number of hinges per door.

Trial application recommended

Thick door - twin application

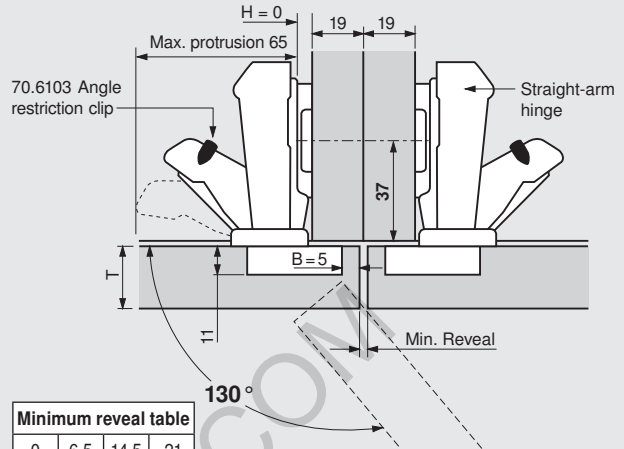

Minimum reveal table			
0	6.5	14.5	21
22	25	29	32
T Door thickness			

Trial application recommended

Lip door application

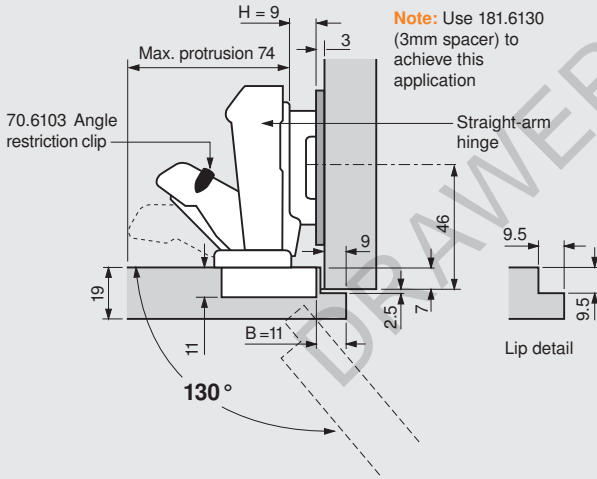

Note: Use 181.6130 (3mm spacer) to achieve this application

Trial application recommended

Mitered corner door application

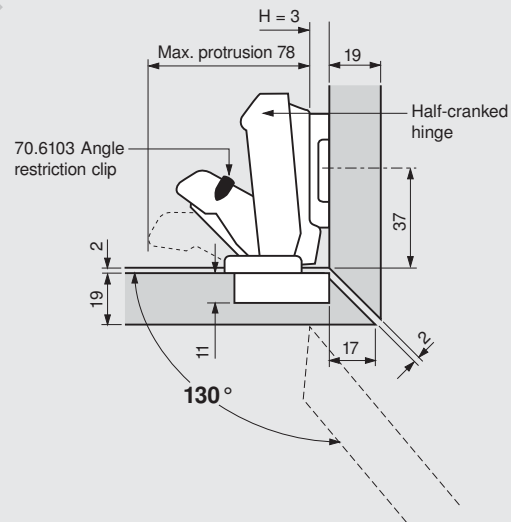

Trial application recommended

NOTE: These applications can be achieved in face frame cabinets by blocking out behind the frame.

Angle restriction clip



- Reduces opening angle of the CLIP top and CLIP 170° to 130°
- See page 31
- Black nylon

Angle restriction clip

70.6103

3 mm spacer



- Mounts under CLIP plates
- Reduces overlay by 3 mm
- Brown nylon

3 mm spacer

181.6130



CLIP top 110° special application hinges



Features

- 110° opening angle
- For door thicknesses up to 26 mm, for thicker doors use the Thick door hinge page 18
- For larger overlays (max. 21 mm)
- All metal hinge, nickel plated
- Straight-arm hinge only
- Available with INSERTA tool-free attachment

NOTE: See next page for special thick door req.

Minimum Reveal (see next page)

Minimum reveal table

2.0	3.4	4.6	6.1	3
2.0	3.2	4.4	5.7	4
2.0	3.1	4.2	5.4	5
1.9	3.0	4.0	5.1	6
19	22	24	26	B
T	Door thickness			Bore

Cross-reference the door thickness and bore distance to assure that doors won't bind when opened.

For door thickness greater than 30 mm trial application recommended.

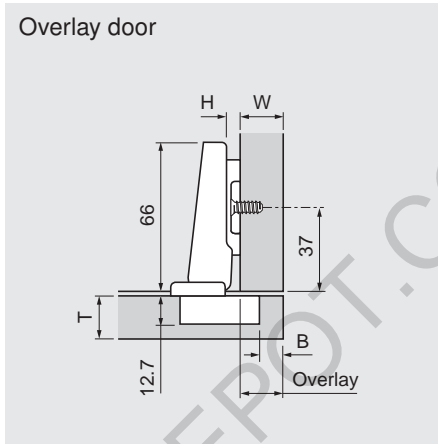
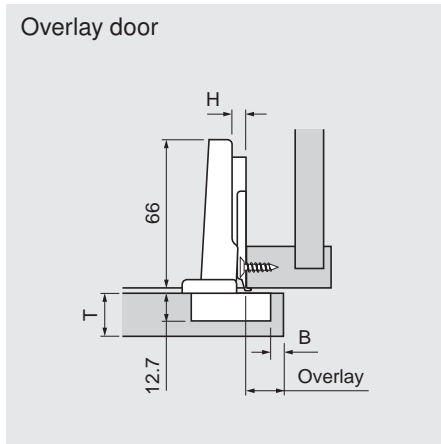

Straight-arm hinges

	Self close
Screw-on	73T5550.22
Press-in	73T5580.22
INSERTA	73T5590B22

Overlay table						
0	16	17	18	19	9.5	19
3	13	14	15	16	12.5	22
4.5	11.5	12.5	13.5	14.5	14	23.5
6	10	11	12	13	15.5	25
9	7	8	9	10	18.5	28
H	3	4	5	6	P	S
Plate	B Bore distance				Clearance	

NOTE: 4.5 plate only available for face frame, 9 plate only available for panel cabinets

13 fixed distance

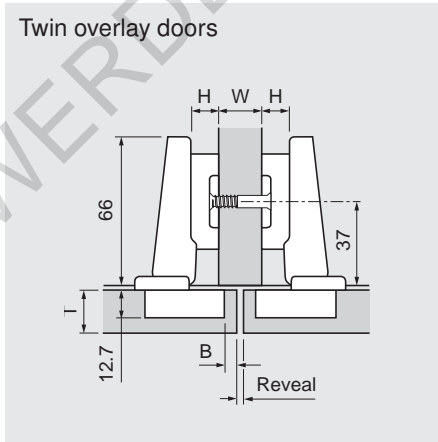
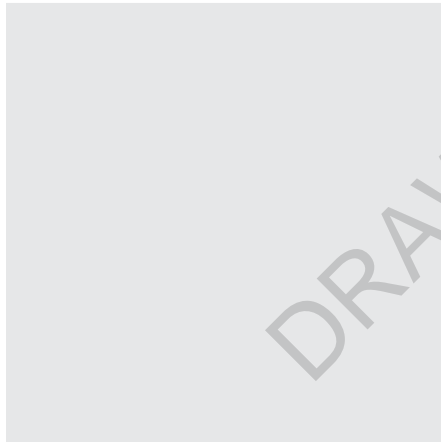

Straight-arm hinges

	Self close
Screw-on	73T5550.22
Press-in	73T5580.22
INSERTA	73T5590B22

Reveal table					Twin overlay	
9	2	-	-	-	16	
	5	3	-	-	19	18.5 28
	8	6	4	-	22	
H	3	4	5	6	W	P S
Plate	B Bore distance				Clearances	

4 fixed distance

Building both frame and panel cabinets

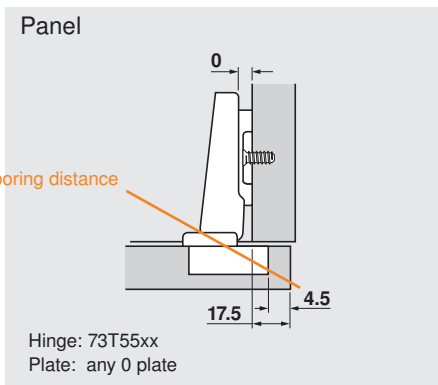
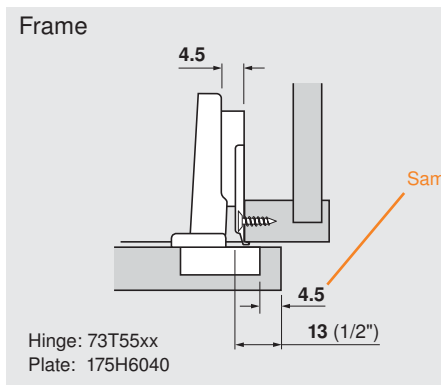

Same boring distance

The most common overlays for frame and panel cabinets can be achieved by using the same machine setting for hinge cup boring.

- Bore **ALL** doors at 4.5 mm to achieve:
 - 13 (1/2") overlay on frame cabinets and
 - 17.5 (11/16") overlay on panel cabinets

Use hinge/plate combinations to the left.

Advantages:

- Only one machine setting for boring all doors (4.5 mm)
- Same hinge used for both applications (73T55xx)

For more information on using this section see page 5.

All dimensions in millimeters.

Subject to technical modifications without notice. © 2008

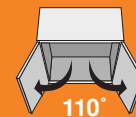

CLIP top 110° special applications

CLIP top/CLIP

Minimum reveals increase with door thickness. The following applications show common examples of necessary reveal and door gap for each door thickness.

NOTE: All dimensions are based on a 1 mm door radius.

3/4" thick door applications

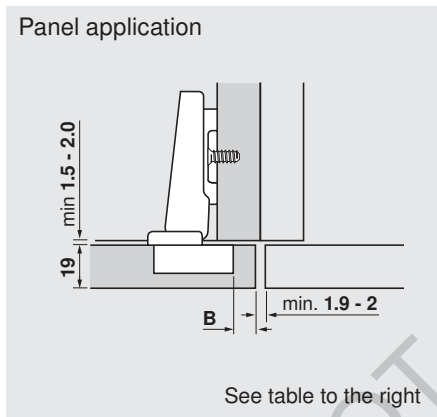
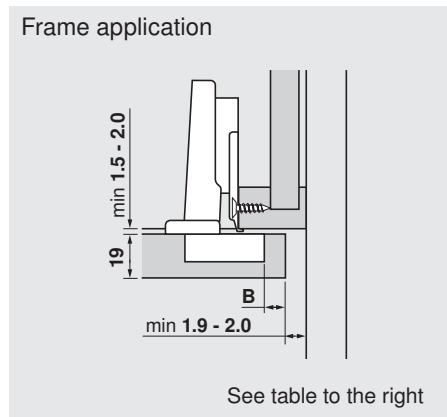

The factory setting for the door gap (distance between the door and side panel/frame) is 1.5 mm. The gap behind the door and the minimum reveal must be adjusted according to the table below, for full opening angle without contacting the side panel or frame.

Minimum reveal	B Bore	Minimum gap behind door *
2.0	3	1.5
2.0	4	1.5
2.0	4.5	1.5
2.0	5	1.5
1.9	6	2.0

* Factory setting is 1.5, may require adjustment

7/8" thick door applications

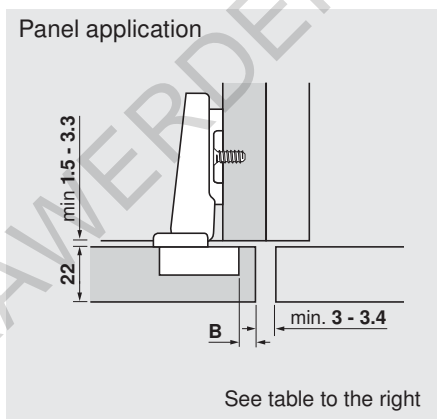
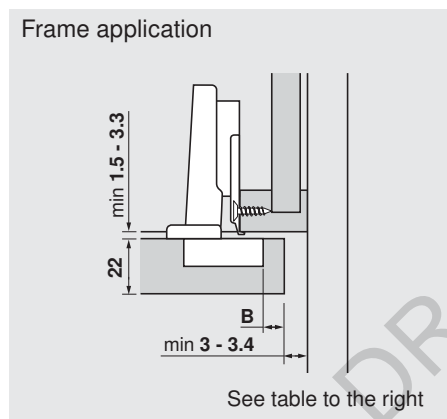

The factory setting for the door gap (distance between the door and side panel/frame) is 1.5 mm. The gap behind the door and the minimum reveal must be adjusted according to the table below, for full opening angle without contacting the side panel or frame.

Minimum reveal	B Bore	Minimum gap behind door *
3.4	3	1.5
3.2	4	1.5
3.2	4.5	1.7
3.1	5	2.2
3.0	6	3.3

* Factory setting is 1.5, may require adjustment

1" thick door applications

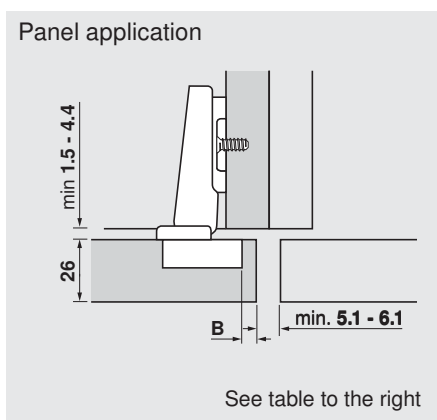
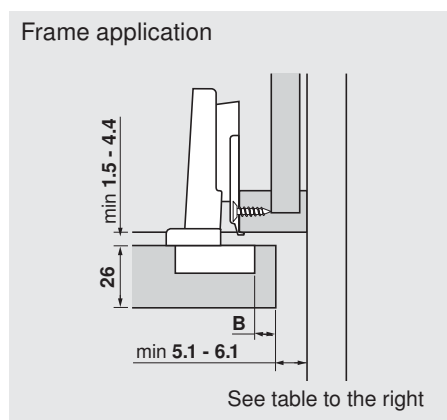

The factory setting for the door gap (distance between the door and side panel/frame) is 1.5 mm. The gap behind the door and the minimum reveal must be adjusted according to the table below, for full opening angle without contacting the side panel or frame.

Minimum reveal	B Bore	Minimum gap behind door *
6.1	3	1.5
5.7	4	2.5
5.6	4.5	3.0
5.4	5	3.4
5.1	6	4.4

* Factory setting is 1.5, may require adjustment



CLIP top 95° thick door hinges



CLIP top/CLIP



Features

- 95° opening angle
- Three-dimensional adjustment
- All metal hinge, nickel plated
- Available with INSERTA tool-free attachment

Cover caps
Mounting plates

page 31
pages 47-52

Minimum Reveal

Minimum reveal table									
0.4	0.9	1.3	1.8	2.6	3.1	3.8	3	Cross-reference the door thickness and bore distance to assure that doors won't bind when opened.	
0.4	0.9	1.3	1.8	2.5	2.9	3.5	4		
0.4	0.9	1.3	1.8	2.4	2.8	3.3	5		
0.4	0.9	1.3	1.8	2.3	2.7	3.2	6		
0.4	0.9	1.2	1.7	2.2	2.6	3.1	7		
19	22	24	26	28	29	30	B		
								T Door thickness	

See back cover fold out for more specifications →

Frame cabinet applications

Overlay door

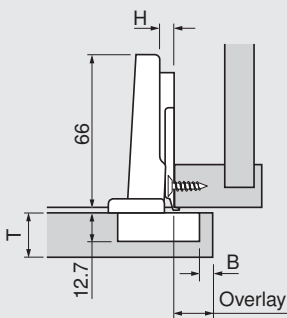

Panel cabinet applications

Overlay door

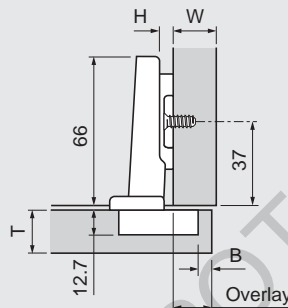

Straight-arm hinges

	Self close	Free swing
Screw-on	71T9550	70T9550.TL
Press-in 	71T9580	70T9580.TL
INSERTA	71T9590B	-

Overlay table									
0	14	15	16	17	18	14.5	22		
3	11	12	13	14	15	17.5	25		
4.5	9.5	10.5	11.5	12.5	13.5	19	26.5		
6	8	9	10	11	12	20.5	28		
9	5	6	7	8	9	23.5	31		
H	3	4	5	6	7	P	S		
Plate	B Bore distance					Clearances			

11 fixed distance

NOTE: 4.5 plate only available for face frame, 9 plate only available for panel cabinets

Partial overlay door

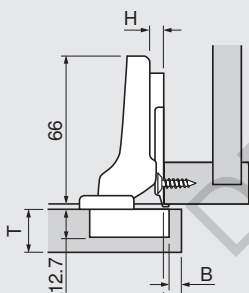

Twin overlay doors

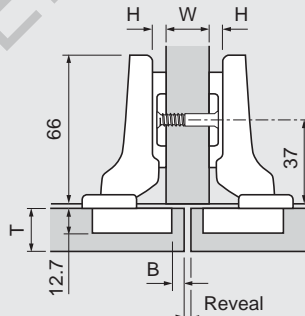

Half-cranked hinges (9.5 mm)

	Self close	Free swing
Screw-on	71T9650	70T9650.TL
Press-in 	71T9680	-
INSERTA	71T9690B	-

Overlay table							Partial overlay		
0	4.5	5.5	6.5	7.5	8.5	24	31		
H	3	4	5	6	7	P	S		
Plate	B Bore distance					Clearances			

1.5 fixed distance

Reveal table							Twin overlay			
0	7	5	3	1	-	16	24	31		
	10	8	6	4	2	19				
	13	11	9	7	5	22				
H	3	4	5	6	7	W	P	S		
Plate	B Bore distance					Panel	Clearances			

Inset door

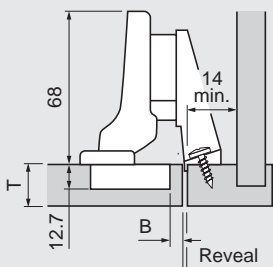

NOTE: For this application use a half-cranked hinge from above and mounting plate 175H5030.21

Inset door

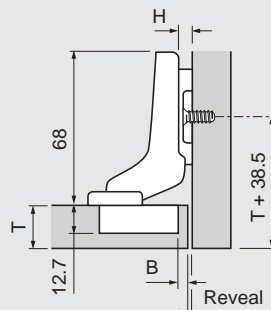

Full-cranked hinges (18 mm)

	Self close	Free swing
Screw-on	71T9750	70T9750.TL
Press-in 	71T9780	-
INSERTA	71T9790B	-

Reveal table									
0	4	3	2	1	-	32.5	40		
H	3	4	5	6	7	P	S		
Plate	B Bore distance					Clearances			

- 7 fixed distance

For more information on using this section see page 5.

All dimensions in millimeters.

Subject to technical modifications without notice. © 2008



CLIP top zero protrusion hinges

CLIP top/CLIP



Features

- 155° opening angle
- Three-dimensional adjustment
- All metal hinge, nickel plated
- Available with INSERTA tool-free attachment
- For cabinets with interior drawers

Cover caps
Mounting plates

page 31
pages 47-52

Minimum Reveal

Minimum reveal table						
0	0	0	0	0	0	3
0	0	0	0	0	0	4
0	0	0	0	0	0	5
0	0	0	0	0	0	6
16	18	19	20	22	24	B
T Door thickness						Bore

No minimum reveal required for door thicknesses of up to 24 mm

See back cover fold out for more specifications →

Frame cabinet applications

Overlay door

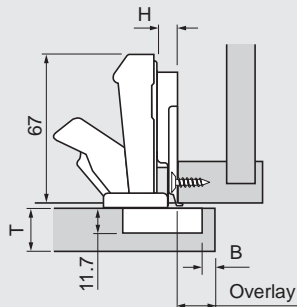

NOTE: 175H6xxx or 175L6600.24 recommended

Panel cabinet applications

Overlay door

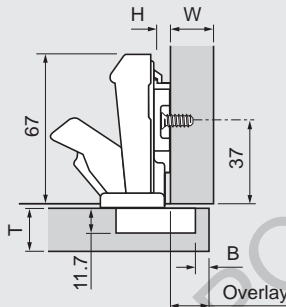

Straight-arm hinges

	Self close
Screw-on	71T7500B
Press-in	71T7530B
INSERTA	71T7540B

Overlay table						
0	14	15	16	17	-2.3	56
3	11	12	13	14	.7	56
H	3	4	5	6	P	S
Plate	B	Bore distance			Clearances	

11 fixed distance

Door protrusion

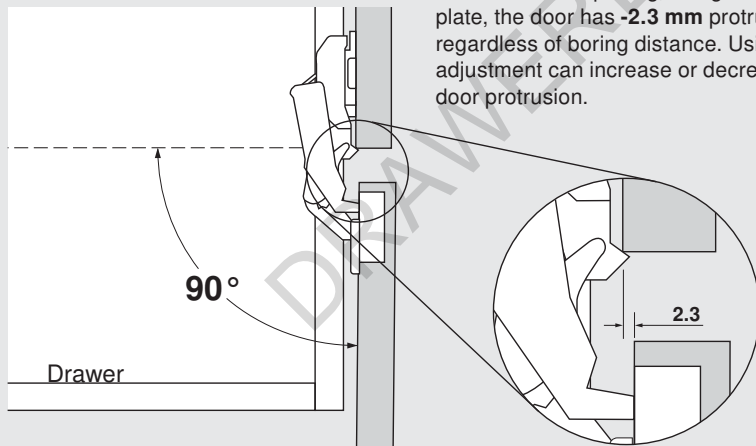

NOTE: At 90° opening, using a 0 mm plate, the door has -2.3 mm protrusion regardless of boring distance. Using side adjustment can increase or decrease door protrusion.

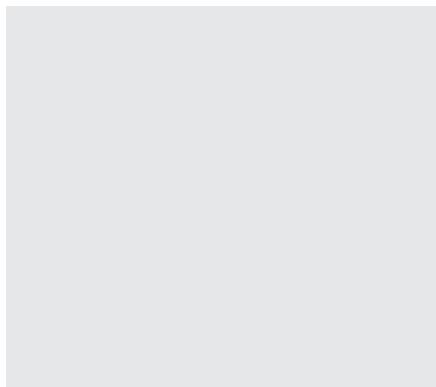
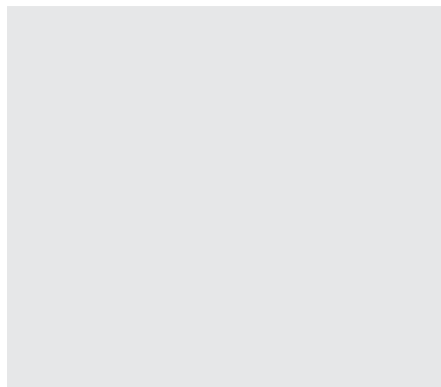

CLIP top 120° aluminum door hinges for BLUMOTION



CLIP top/CLIP



Features

- Narrow aluminum door hinge for use with BLUMOTION 973A
- 120° opening angle
- Three-dimensional adjustment
- All metal hinge, nickel plated
- No change to aluminum door drilling

Cover caps
Mounting plates

page 31

pages 47-52

Minimum Reveal

Minimum reveal table					
1.5	1.9	2.4	2.9	3.7	18
1.5	1.8	2.2	2.7	3.3	19
1.4	1.8	2.2	2.6	3.1	20
1.4	1.7	2.1	2.5	3	21
1.2	1.7	2	2.4	2.9	22
18	19	20	21	22	Door Frame Width
T Door thickness					

Cross-reference the door thickness and bore distance to assure that doors won't bind when opened.

Specifications

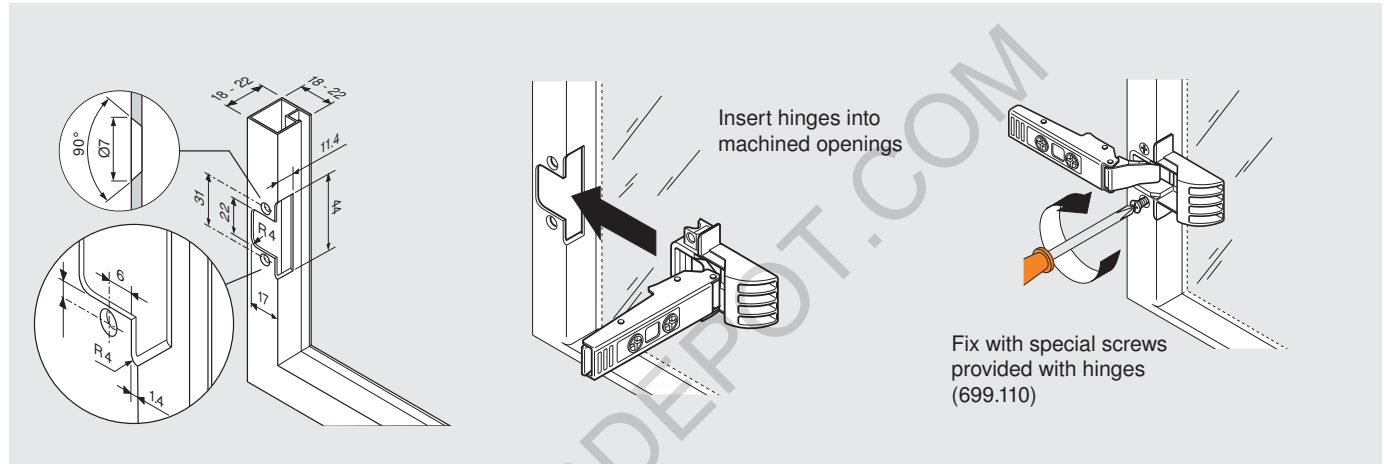

Applications

Overlay door - frame cabinets

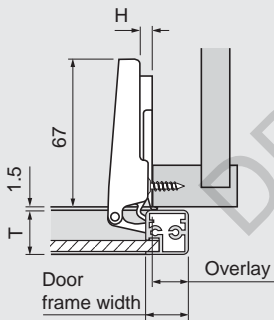

Overlay door - panel cabinets

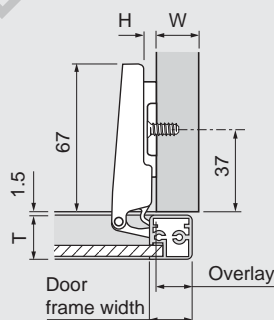

Partial overlay door - panel cabinets

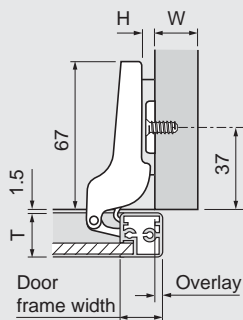

Twin doors - panel cabinets

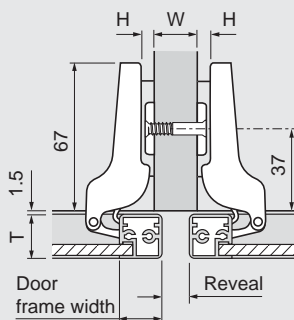

Straight-arm hinges

Self close

Screw-on **73T550AB**

Overlay table			
0	15	8	19.5
3	12	11	22.5
4.5	10.5	12.5	24
6	9	14	25.5
9	6	17	28.5
H Plate	Fixed Bore distance	P Clearances	S Clearances

NOTE: 4.5 plate only available for face frame, 9 plate only available for panel cabinets

Half-cranked hinges (9.5 mm)

Self close

Screw-on **71T560AB**

Overlay table			
0	3.5	19.5	31
H Plate	Fixed Bore distance	P Clearances	S Clearances

Reveal table				
0	9	16	19.5	31
	12	19	19.5	31
H Plate	Fixed Bore distance	W Panel	P Clearances	S Clearances

For more information on using this section see page 5.
All dimensions in millimeters. (inch equivalents as shown).
Subject to technical modifications without notice. © 2007

CLIP top 120° aluminum door hinges

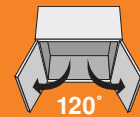

CLIP top/CLIP



Features

- 120° opening angle
- Three-dimensional adjustment
- All metal hinge, nickel plated
- Contact Blum for aluminum door suppliers

Cover caps
Mounting plates

page 31
pages 47-52

Minimum Reveal

Minimum reveal table					
1.5	1.9	2.4	2.9	3.7	18
1.5	1.8	2.2	2.7	3.3	19
1.4	1.8	2.2	2.6	3.1	20
1.4	1.7	2.1	2.5	3	21
1.2	1.7	2	2.4	2.9	22
18	19	20	21	22	Door Frame Width
T Door thickness					

Cross-reference the door thickness and bore distance to assure that doors won't bind when opened.

See back cover fold out for more specifications →

Specifications

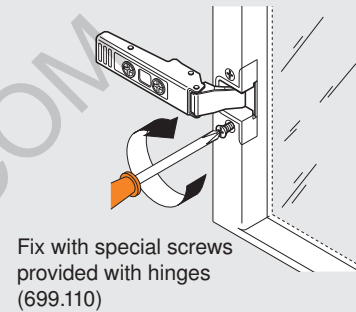
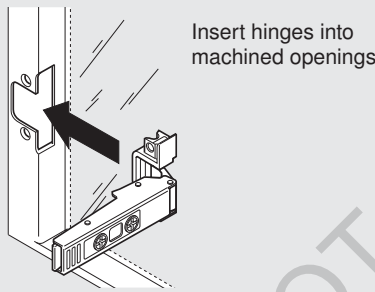
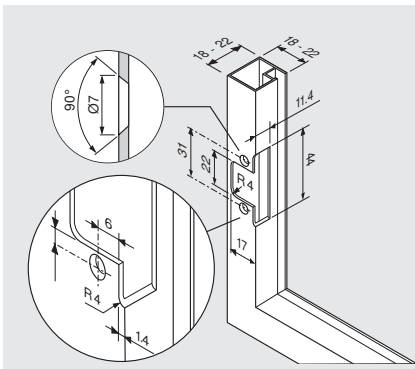

Applications

Overlay door - frame cabinets

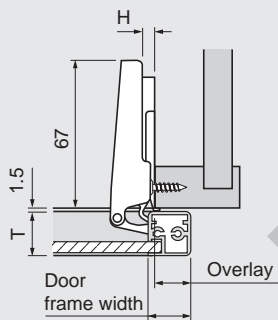

Overlay door - panel cabinets

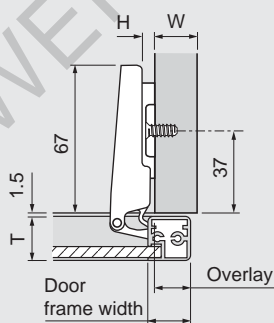

Partial overlay door - panel cabinets

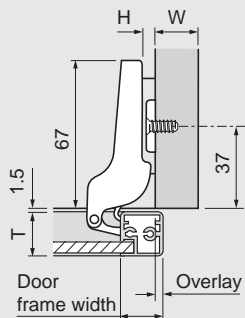

Twin doors - panel cabinets

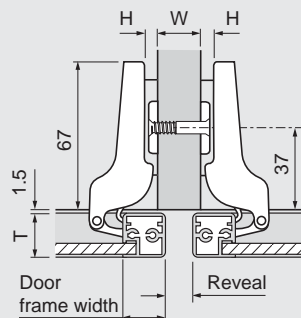

Straight-arm hinges

	Self close	Free swing
Screw-on	73T550A	72T550A.TL

Overlay table			
0	15	8	19.5
3	12	11	22.5
4.5	10.5	12.5	24
6	9	14	25.5
9	6	17	28.5
H Plate	Fixed Bore distance	P Clearances	S Clearances

NOTE: 4.5 plate only available for face frame, 9 plate only available for panel cabinets

Half-cranked hinges (9.5 mm)

	Self close
Screw-on	71T560A

Overlay table			
0	3.5	19.5	31
H Plate	Fixed Bore distance	P Clearances	S Clearances

Reveal table				
0	9	16	19.5	31
	12	19	19.5	31
H Plate	Fixed Bore distance	W Panel	P Clearances	S Clearances

For more information on using this section see page 5.

All dimensions in millimeters.

Subject to technical modifications without notice. © 2008





CLIP top inset blind corner hinges



Features

- 95° opening angle
- Three-dimensional adjustment
- All metal hinge, nickel plated
- Available with INSERTA tool-free attachment
- Fix with special screws provided with hinges (699.110)

Cover caps
Mounting plates

page 31
pages 47-52

Minimum Reveal

Minimum reveal table						
0.1	0.3	0.4	0.5	0.9	1.3	3
0.1	0.3	0.4	0.5	0.9	1.3	4
0.1	0.4	0.4	0.5	0.9	1.3	5
0.1	0.3	0.4	0.5	0.9	1.2	6
0.1	0.3	0.4	0.5	0.9	1.2	7
16	18	19	20	22	24	B
T Door thickness						Bore

Cross-reference the door thickness and bore distance to assure that doors won't bind when opened.

CLIP top/CLIP

Flush door applications

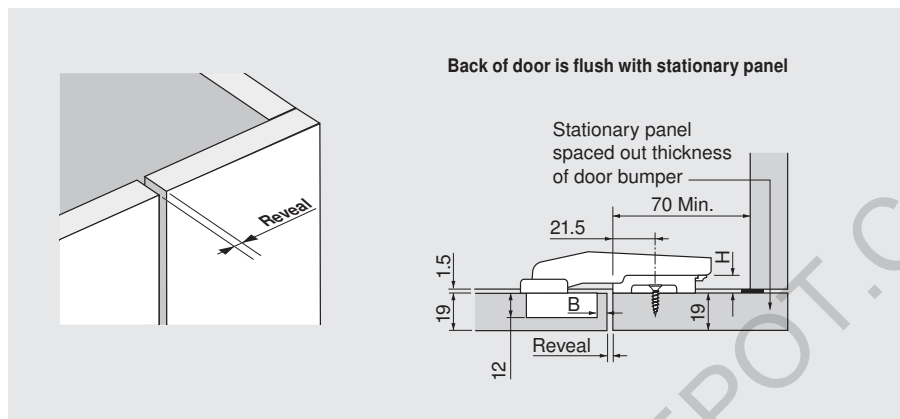

Inset blind corner hinges

	Self close
Screw-on	79T9550
Press-in 	79T9580
INSERTA	79T9590B

Reveal table							
3	5	4	3	2	1	33.5	21
H	3	4	5	6	7	P	S
Plate	B Bore distance					Clearances	

Offset door applications

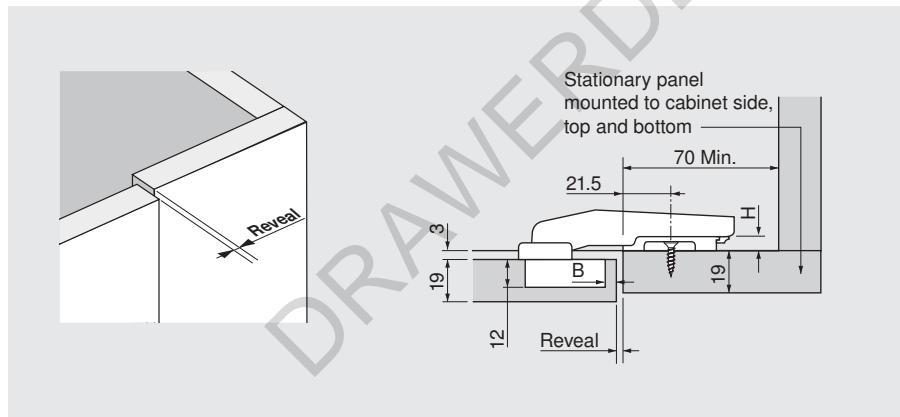

Inset blind corner hinges

	Self close
Screw-on	79T9550
Press-in 	79T9580
INSERTA	79T9590B

Reveal table							
0	5	4	3	2	1	33.5	18
H	3	4	5	6	7	P	S
Plate	B Bore distance					Clearances	

Adjustments and clearances

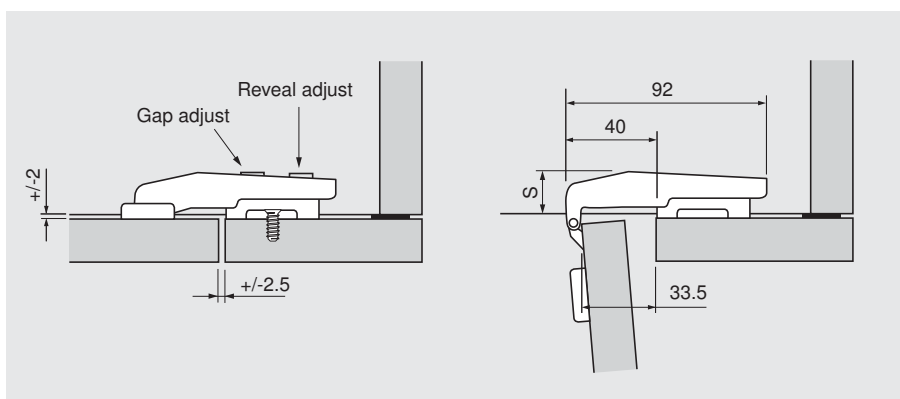

For more information on using this section see page 5.

All dimensions in millimeters.

Subject to technical modifications without notice. © 2008



CLIP top diagonal 45° hinges

CLIP top/CLIP



Features

- 110° opening angle
- Three-dimensional adjustment
- All metal hinge, nickel plated
- Available with INSERTA tool-free attachment

Cover caps
Mounting plates

page 31
pages 47-52

Applications

See back cover fold out for more specifications →

Overlay application

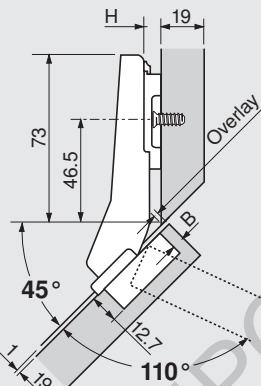
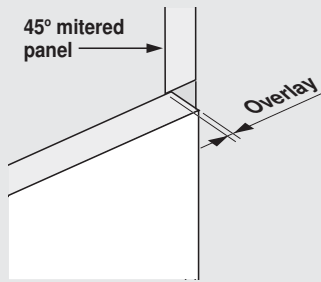

Inside corner

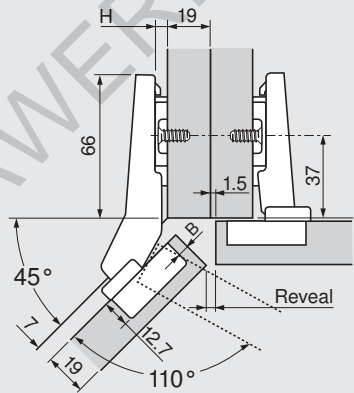
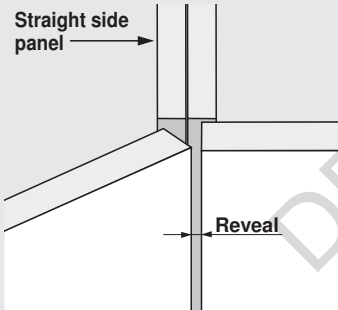

Calculating door width (DW)

Step 1: Using the Boring distance (B) determined in the reveal table, cross-reference to find the side gap distance (Y) in the table to the right.

Step 2: Use the following formula to find the door width: $DW = IW - (Y \times 2)$

Example:

Int. width (IW) = 400mm
Side gap (Y) = 4.5 mm
 $391 = 400 - (4.5 \times 2)$

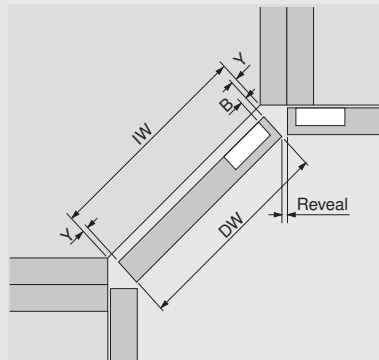

Diagonal 45 hinges

	Self close
Screw-on	79T5550
Press-in	79T5580
INSERTA	79T5590B

Overlay table				
0	1	2	3	4
H	3	4	5	6
Plate	B Bore distance			

Diagonal 45 hinges

	Self close
Screw-on	79T5550
Press-in	79T5580
INSERTA	79T5590B

Reveal table				
0	6	5	4	3
H	3	4	5	6
Plate	B Bore distance			

NOTE: Reveal based on 19 (3/4") side panel

Y Side Gap			
5.5	4.5	3.5	2.5
3	4	5	6
B Bore distance			

NOTE: Calculations based on 19 (3/4") door thickness.



CLIP top overlay blind corner hinges

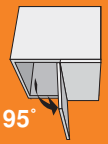

CLIP top/CLIP



Features

- 95° opening angle
- Three-dimensional adjustment
- All metal hinge, nickel plated
- Available with INSERTA tool-free attachment

Cover caps
Mounting plates

page 31
pages 47-52

Minimum Reveal

Minimum reveal table							
0.1	0.3	0.4	0.5	0.9	1.3	3	Cross-reference the door thickness and bore distance to assure that doors won't bind when opened.
0.1	0.3	0.4	0.5	0.9	1.3	4	
0.1	0.3	0.4	0.5	0.9	1.3	5	
0.1	0.3	0.4	0.5	0.9	1.2	6	
0.1	0.3	0.4	0.5	0.9	1.2	7	
16	18	19	20	22	24	B	Bore
T Door thickness							

See back cover fold out for more specifications →

Overlay application

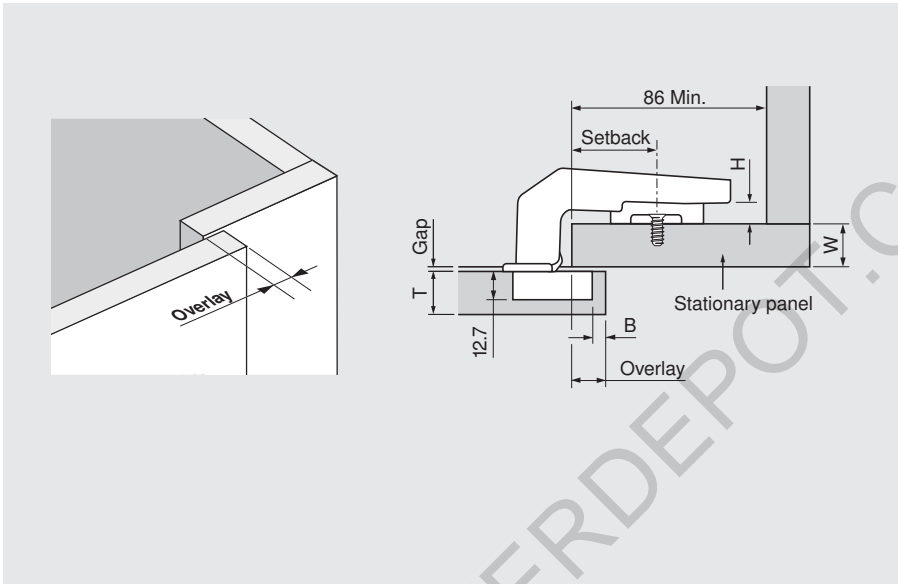

Overlay blind corner hinges

	Self close
Screw-on	79T9950.37
Press-in	79T9980.37
INSERTA	79T9990B37

Door Overlay

The door overlay varies depending on the setback position of the mounting plate. Use the table below to select the desired overlay and cross-reference to the plate setback and bore distance.

Overlay table							
27	2	3	4	5	6	7	32
32	7	8	9	10	11	12	27
37	12	13	14	15	16	17	22
Plate Setback	3	4	5	6	7	P	A
	B Bore distance					Clearances	

9 fixed distance

Adjustments and clearances

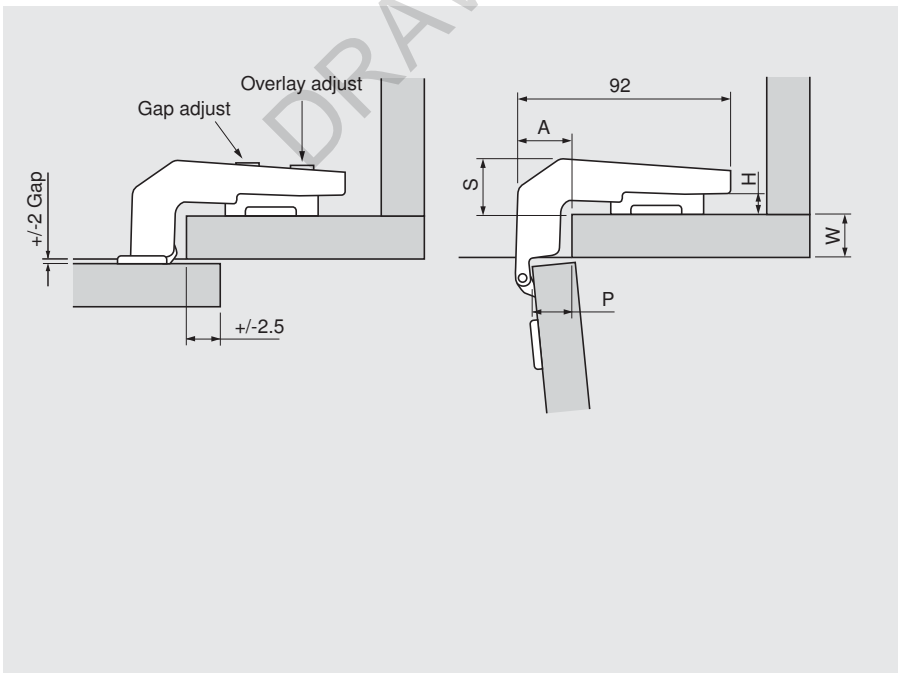

Door Gap

The door gap varies depending on the thickness of the stationary panel and the height of the mounting plate. Using the table below:

1. Select a panel thickness column.
2. Choose a door gap.
3. Cross-reference the plate height.

Gap table				
0	7	4	1	21
3	4	1	-	24
6	1	-	-	27
H	16	19	22	S
Plate	W panel thk.		Clearances	

NOTE: Door gap can be adjusted ±2.



CLIP top mini hinges

CLIP top/CLIP



Features

- 94° opening angle
- Side adjustment of +0.5 to -3.5 mm
- Hinge for small doors or doors with small frames
- **Must use 26 mm drill bit (1" cannot be used)**

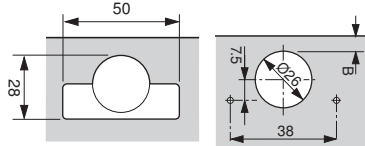

Minimum Reveal

Minimum reveal table							
1.1	2.2	3.0	3.8	5.5	7.3	9.1	3
1.1	2.0	2.7	3.5	5.0	6.8	8.6	4
1.1	1.8	2.4	3.0	4.6	6.3	8.0	5
16	18	19	20	22	24	26	B
T Door thickness							Bore

Cross-reference the door thickness and bore distance to assure that doors won't bind when opened.

See back cover fold out for more specifications →

Frame cabinet applications

Overlay door

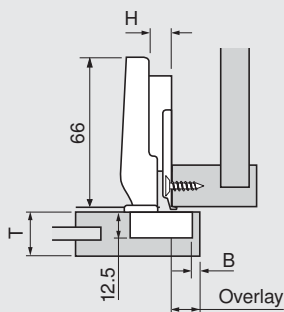

Panel cabinet applications

Overlay door

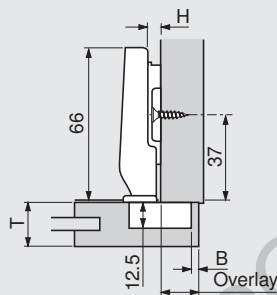

Straight-arm hinges

Self close
Screw-on **71T0550**

Overlay table						
0	13	14	15	6	19	
3	10	11	12	9	22	
4.5	8.5	9.5	10.5	11	23.5	
6	7	8	9	12	25	
9	4	5	6	15	28	
H	3	4	5	P	S	
Plate	B Bore distance			Clearances		

10 fixed distance

NOTE: 4.5 plate only available for face frame, 9 plate only available for panel cabinets

Partial overlay door

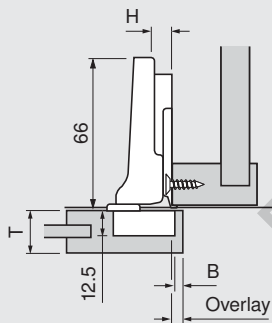

Twin overlay doors

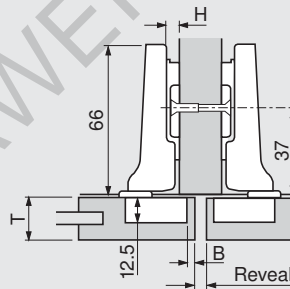

Half-cranked hinges (9.5 mm)

Self close
Screw-on **71T0650**

Overlay table						Partial overlay
0	3.5	4.5	5.5	15.5	24	
H	3	4	5	P	S	
Plate	B Bore distance			Clearances		

.5 fixed distance

Reveal table						Twin overlay
0	9	7	5	16		
	12	10	8	19	15.5	25
	15	13	11	22		
H	3	4	5	W	P	S
Plate	B Bore distance			Panel	Clearances	

Inset door

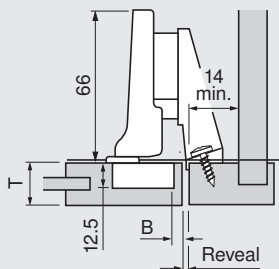

NOTE: For this application use a half-cranked hinge from above and mounting plate 175H5030.21

Inset door

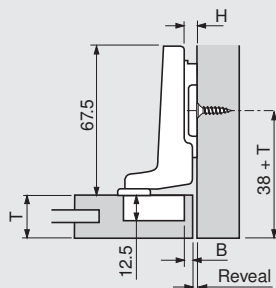

Full-cranked hinges (18 mm)

Self close
Screw-on **71T0750**

Reveal table					
0	5	4	3	24	32
H	3	4	5	P	S
Plate	B Bore distance			Clearances	

- 8 fixed distance

For more information on using this section see page 5.

All dimensions in millimeters.

Subject to technical modifications without notice. © 2008

CLIP top glass door hinges



CLIP top/CLIP



Features

- 94° opening angle
- Three-dimensional adjustment
- For glass thickness of 4.5 to 7 mm
- Side adjustment of +.5 to -3.5 mm
- Fixing screws included (605.1100)
- **Must use 26 mm drill bit (1" cannot be used)**

Cover caps
Mounting plates

page 31
pages 47-52

Minimum Reveal

Minimum reveal table				
0	0	0	0	5.5
0	0	0	0	6
0	0	0	0	6.5
0	0	0	0	7
4.5	5	6	7	B
T Door thickness				Bore

Cross reference the door thickness and bore distance to assure that doors won't bind when opened.

Frame cabinet applications

Boring pattern

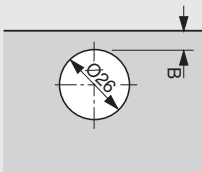

Panel cabinet applications

Overlay door

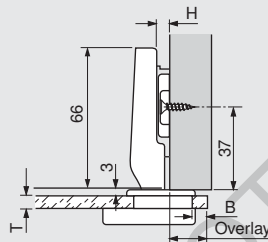

See back cover fold out for more specifications →

Straight-arm hinges

Self close
Screw-on **75T4100**

Overlay table						
0	15.5	16	16.5	17	6	19
3	12.5	13	13.5	14	9	22
6	9.5	10	10.5	11	12	25
9	6.5	7	7.5	8	15	28
H	5.5	6	6.5	7	P	S
Plate	B Bore distance			Clearances		

10 fixed distance

Cover caps for door front (required)

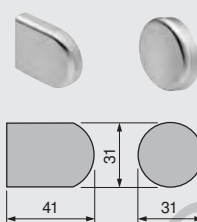

Both available in:
G = Gold polished
S = Black
CR = Chrome polished

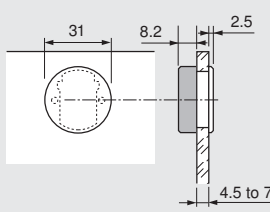

D - shape	84.4120
Round	84.4140

Twin overlay doors

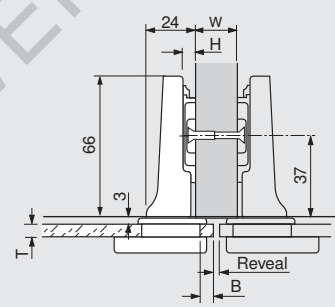

Half-cranked hinges (9.5 mm)

Self close
Screw-on **75T4200**

Reveal table					Twin overlay	
0	4	3	1	.5	16	24
	7	6	5	4	19	15
	10	9	8	7	22	
H	5.5	6	6.5	7	W	P S
Plate	B Bore distance			Panel	Clearances	

.5 fixed distance

Inset door

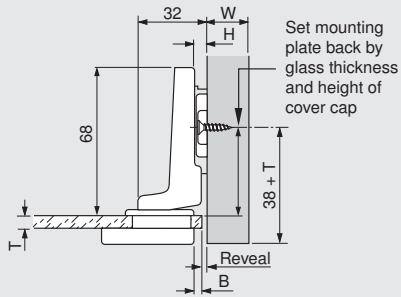

Set mounting plate back by glass thickness and height of cover cap

Full-cranked hinges (18 mm)

Self close
Screw-on **75T4300**

Reveal table					
0	2.5	2	1.5	1	23.5 32
H	5.5	6	6.5	7	P S
Plate	B Bore distance			Clearances	

- 8 fixed distance

For more information on using this section see page 5.
All dimensions in millimeters.
Subject to technical modifications without notice. © 2008





CLIP top bi-fold hinges

CLIP top/CLIP



Features

- New spiral tech side adjustment for door gap
- Spiral tech depth adjustment for in / out
- 60° opening angle
- Four-dimensional adjustment
- All metal hinge, nickel plated

Cover caps
Mounting plates

page 31
pages 47-52

Application

Inside corner

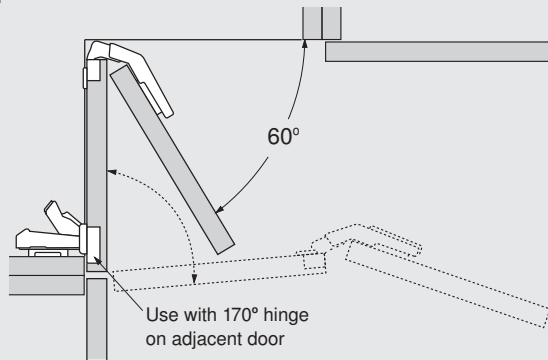

Bi-fold hinges

	Self close
Screw-on	79T8500.10
Press-in 	79T8530.10

General specifications

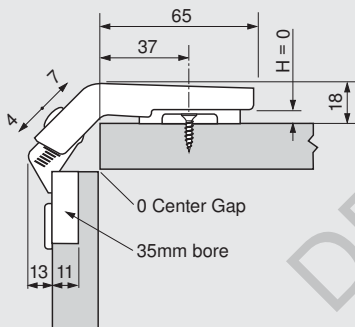

With flat panel doors

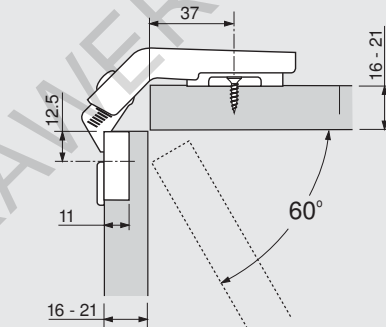

With profile doors

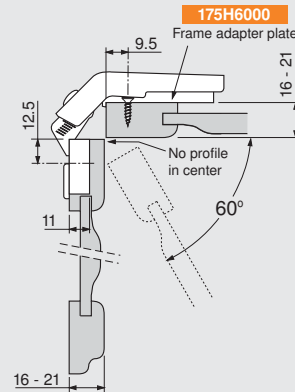

Calculating door sizes

The doors for a CLIP top bi-fold application can be of equal or unequal width. To calculate the door width (DW) of each door:

Step 1: Add the interior width (IW) to the side panel width (W).

Step 2: Subtract door thickness (T) and reveal (R).

Step 3: Subtract gap (G) and bumper thickness behind adjacent door.

Formula: $DW = (IW + W) - T - R - G$

Example: $DW = (500 + 19) - 19 - 3 - 1$
 $DW = 496 \text{ mm}$

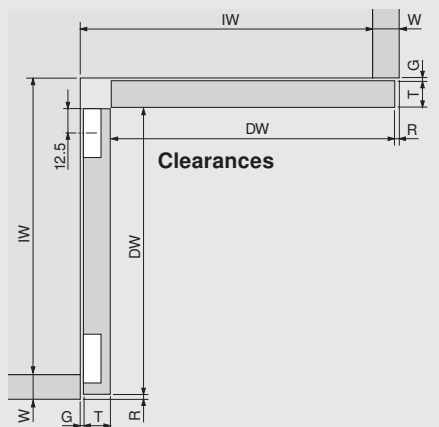

Adjustment

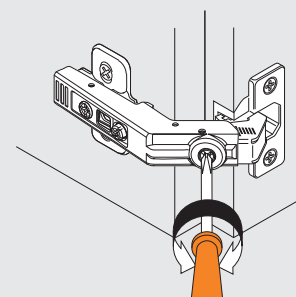

The new spiral tech cam adjustment of the CLIP top bi-fold hinge allows from +4 mm to -7 mm adjustment.



CLIP 100° hinges



Features

- 100° opening angle
- Three-dimensional adjustment
- All metal hinge, nickel plated
- Available with INSERTA tool-free attachment

Cover caps
Mounting plates

page 31
pages 47-52

Minimum Reveal

Minimum reveal table						
0.5	0.9	1.1	1.4	2.3	3.6	3
0.5	0.8	1.0	1.3	2.0	3.3	4
0.4	0.8	1.0	1.2	1.8	3.0	5
0.4	0.8	.9	1.1	1.7	2.8	6
16	18	19	20	22	24	B
T Door thickness						Bore

Cross-reference the door thickness and bore distance to assure that doors won't bind when opened.

CLIP top/CLIP

Frame cabinet applications

Overlay door

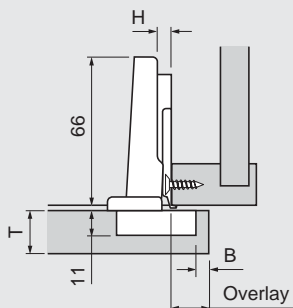

Panel cabinet applications

Overlay door

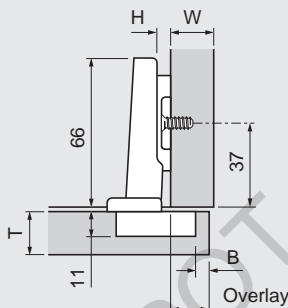

Straight-arm hinges

	Self close	Free swing
Screw-on	71M2550	70M2550.TL
Press-in	71M2580	70M2580.TL
INSERTA	71M2590B	-

Overlay table						
0	14	15	16	17	9	20
3	11	12	13	14	12	23
4.5	9.5	10.5	11.5	12.5	13.5	24.5
6	8	9	10	11	15	26
9	5	6	7	8	18	29
H	3	4	5	6	P	S
Plate	B Bore distance				Clearances	

11 fixed distance

NOTE: 4.5 plate only available for face frame, 9 plate only available for panel cabinets

Half-cranked hinges (9.5 mm)

	Self close	Free swing
Screw-on	71M2650	70M2650.TL
Press-in	71M2680	70M2680.TL
INSERTA	71M2690B	-

Overlay table						Partial overlay	
0	4.5	5.5	6.5	7.5	18.5	30	
H	3	4	5	6	P	S	
Plate	B Bore distance				Clearances		

1.5 fixed distance

Reveal table							Twin overlay	
0	7	5	3	1	16	18.5	30	
	10	8	6	4	19			
	13	11	9	7	22			
H	3	4	5	6	W	P	S	
Plate	B Bore distance				Panel	Clearances		

Full-cranked hinges (18 mm)

	Self close	Free swing
Screw-on	71M2750	70M2750.TL
Press-in	71M2780	70M2780.TL
INSERTA	71M2790B	-

Reveal table						
0	4	3	2	1	27	38
H	3	4	5	6	P	S
Plate	B Bore distance				Clearances	

- 7 fixed distance

Partial overlay door

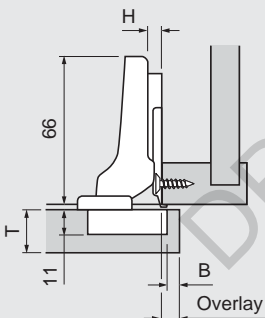

Twin overlay doors

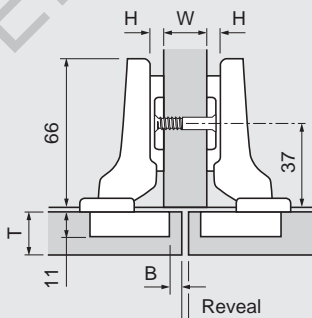

Inset door

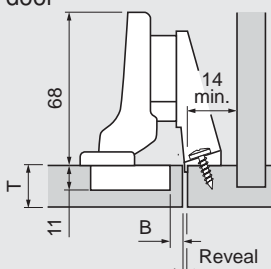

NOTE: For this application use a half-cranked hinge from above and mounting plate 175H5030.21

Inset door

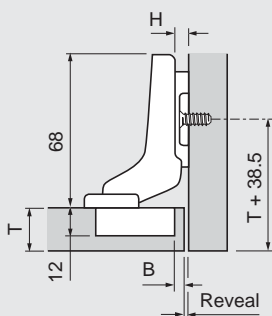

For more information on using this section see page 5.

All dimensions in millimeters.

Subject to technical modifications without notice. © 2008

CLIP 107° hinges



CLIP top/CLIP



Features

- 107° opening angle
- Three-dimensional adjustment
- All metal hinge, nickel plated
- 86° angle restriction clips available (page 31)

Cover caps
Mounting plates

page 31
pages 47-52

Minimum Reveal

Minimum reveal table						
0.6	1.0	1.3	1.7	2.5	3	
0.6	1.0	1.3	1.6	2.4	4	
0.6	1.0	1.2	1.5	2.2	5	
0.6	1.0	1.2	1.4	2.0	6	
16	18	19	20	22	B	
T Door thickness					B Bore	

Cross-reference the door thickness and bore distance to assure that doors won't bind when opened.

Frame cabinet applications

Overlay door

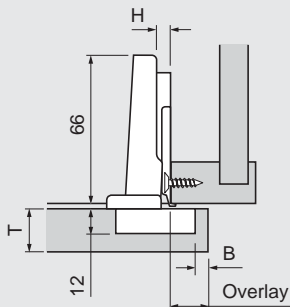

Panel cabinet applications

Overlay door

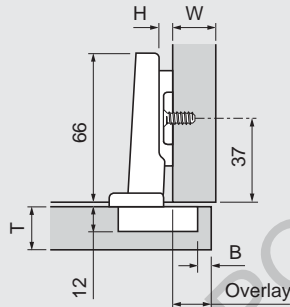

See back cover fold out for more specifications →

Straight-arm hinges

	Self close
Screw-on	75M1550
Press-in	75M1580

Overlay table						
0	14	15	16	17	10	21
3	11	12	13	14	13	24
4.5	9.5	10.5	11.5	12.5	14.5	25.5
6	8	9	10	11	16	27
9	5	6	7	8	19	30
H	3	4	5	6	P	S
Plate	B Bore distance				Clearances	

11 fixed distance

NOTE: 4.5 plate only available for face frame, 9 plate only available for panel cabinets

Partial overlay door

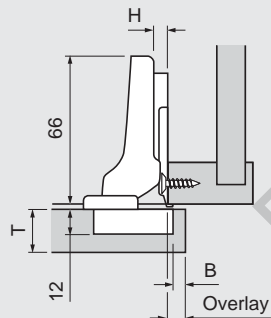

Twin overlay doors

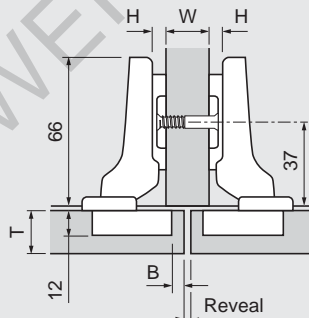

Half-cranked hinges (9.5 mm)

	Self close
Press-in	75M1680

Overlay table						Partial overlay	
0	4.5	5.5	6.5	7.5	20	31	
H	3	4	5	6	P	S	
Plate	B Bore distance				Clearances		

1.5 fixed distance

Reveal table							Twin overlay	
0	7	5	3	1	16	19	20	31
	10	8	6	4	22			
	13	11	9	7				
H	3	4	5	6	W	P	S	
Plate	B Bore distance				Panel	Clearances		

Inset door

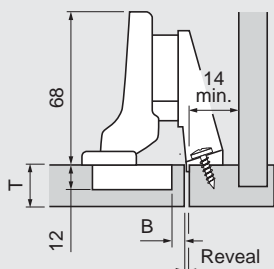

NOTE: For this application use a half-cranked hinge from above and mounting plate 175H5030.21

Inset door

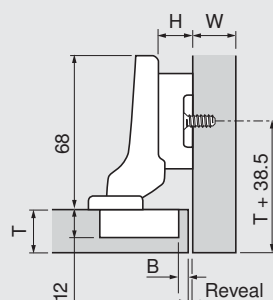

Half-cranked hinges (9.5 mm)

	Self close
Press-in	75M1680

Reveal table						
9	4.5	3.5	2.5	1.5	29	40
H	3	4	5	6	P	S
Plate	B Bore distance				Clearances	

- 7.5 fixed distance



CLIP 170 hinges



Features

- 170° opening angle
- Three-dimensional adjustment
- All metal hinge, nickel plated
- Available with INSERTA tool-free attachment
- 130° angle restriction clips are available (see page 31)

Cover caps
Mounting plates

page 31
pages 47-52

Minimum Reveal

Minimum reveal table						
0	0	0	0	0.2	2.2	3
0	0	0	0	0	1.4	4
0	0	0	0	0	0.9	5
0	0	0	0	0	0	6
0	0	0	0	0	0	7
0	0	0	0	0	0	8
16	18	19	20	22	24	B
T Door thickness						Bore

Cross-reference the door thickness and bore distance to assure that doors won't bind when opened.

CLIP top/CLIP

Frame cabinet applications

Overlay door

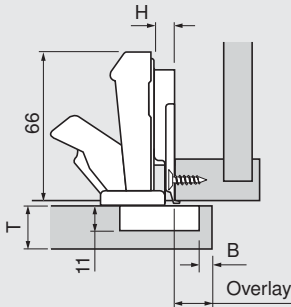

NOTE: 175H6xxx or 175L6600.24 recommended

Panel cabinet applications

Overlay door

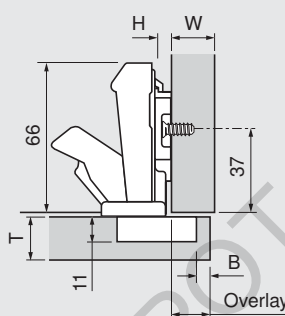

See back cover fold out for more specifications →

Straight-arm hinges

	Self close
Screw-on	71.6550
Press-in	71.6580
INSERTA	71.6540B

Overlay table									
0	14	15	16	17	18	19	1.5	65	
3	11	12	13	14	15	16	4.5	68	
4.5	9.5	10.5	11.5	12.5	13.5	14.5	6	69.5	
6	8	9	10	11	12	13	7.5	71	
9	5	6	7	8	9	10	10.5	74	
H	3	4	5	6	7	8	P	S	
Plate	B Bore distance						Clearances		

11 fixed distance

NOTE: 4.5 plate only available for face frame, 9 plate only available for panel cabinets

Partial overlay door

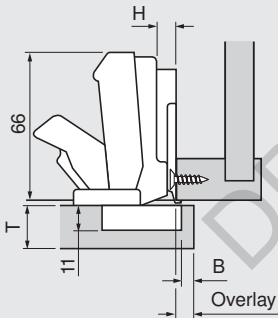

NOTE: 175H6xxx or 175L6600.24 recommended

Twin overlay doors

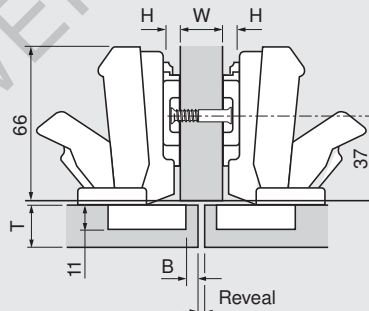

Half-cranked hinges (9.5 mm)

	Self close
Screw-on	71.6650
Press-in	71.6680

Overlay table								Partial overlay	
0	4.5	5.5	6.5	7.5	8.5	9.5	11	75	
H	3	4	5	6	7	8	P	S	
Plate	B Bore distance						Clearances		

1.5 fixed distance

Reveal table							Twin overlay		
0	7	5	3	1	-	-	16	11	75
	10	8	6	4	2	0	19		
	13	11	9	7	5	3	22		
H	3	4	5	6	7	8	W	P	S
Plate	B Bore distance						Panel	Clearances	

NOTE: Inset application not recommended for 170 hinges and face frame adapters

Inset door

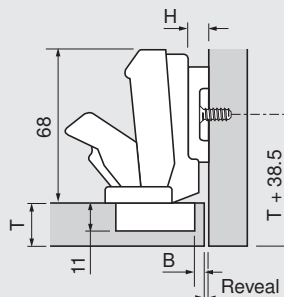

Half-cranked hinges (9.5 mm)

	Self close
Screw-on	71.6650
Press-in	71.6680

Reveal table								
9	4.5	3.5	2.5	1.5	.5	-	20	84
H	3	4	5	6	7	8	P	S
Plate	B Bore distance						Clearances	

- 7.5 fixed distance

For more information on using this section see page 5.

All dimensions in millimeters.

Subject to technical modifications without notice. © 2008





Cover caps and angle restriction clips

Nickel plated steel

Nylon (black or white)

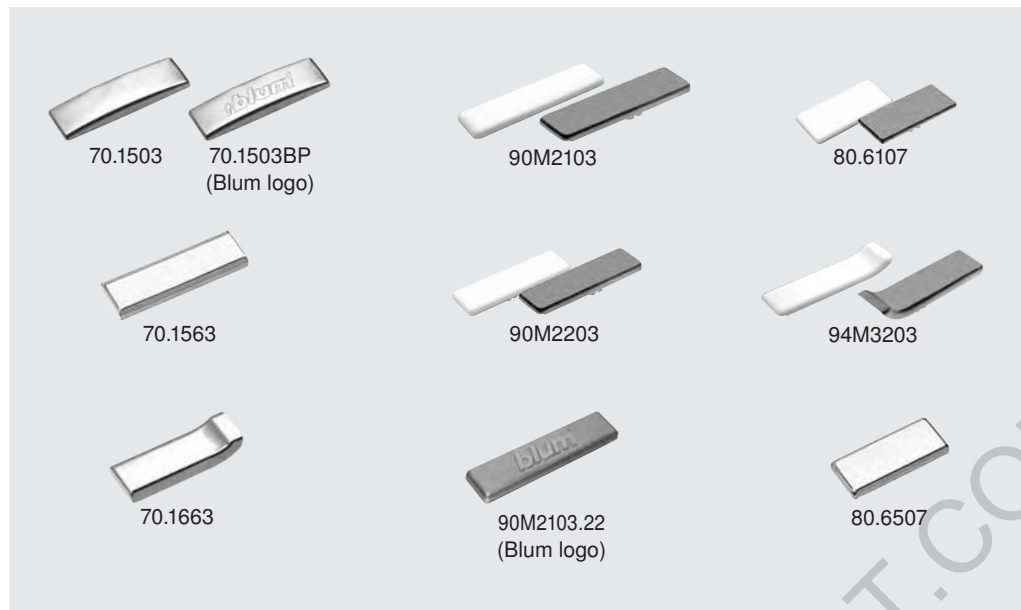
CLIP top hinge cup cover cap

- Elegant design to cover screws
- Clip-on attachment/removal
- Nickel plated steel

For CLIP top hinges only
Suitable for screw-on, press-in and EXPANDO hinge cups for CLIP top 107°, 110°, 120°, 120+°, thick door and blind corner hinges.

Hinge cup cover cap	Part no.
	70T1504

CLIP top / CLIP cover caps

100°, 107°, 120°, 120+, thick door and bi-fold hinges

170° and Zero protrusion hinges

Diagonal 45° and blind corner hinges

Angled, mini and glass door hinges

	Nylon	Steel
Straight-arm	90M2103	70.1503
Cranked-arm	94M3203	70.1663
	80.6107	80.6507
	90M2103	70.1503
Straight-arm	90M2203	70.1563
Cranked-arm	90M2203	70.1563

NOTE: Custom logo available in nylon or nickel plated steel cover caps. Consult your Blum representative for minimum quantities and lead times on custom logos.

Angle restriction clips

For 107° hinges

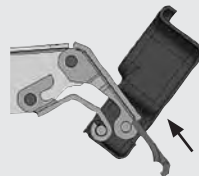
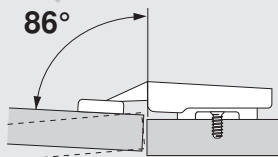

- Reduces opening angle of the CLIP top or CLIP 107° to 86°
- Installs quickly and easily without tools
- Non-removable

Part no.
86° Angle restriction clip **74.1103**

For 170° hinges

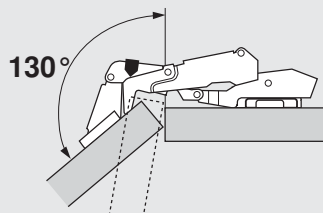

- Reduces opening angle of the CLIP top or CLIP 170° to 130°
- Required for special applications of the 170° hinge
- Installs quickly and easily without tools

Part no.
130° Angle restriction clip **70.6103**



CLIP top angled hinges

CLIP top angled hinge program

Angled



CLIP top hinges from +45° to -45°

Angled hinges provide a tremendous array of possibilities for the cabinet design professional. Specifically designed for panel constructed (frameless) cabinets, the system accommodates cabinet front angles from **-45° to +45°**, in **5°** increments. This is achieved by combining any of twelve angled hinges, or three standard hinges with a wedge spacer and any of five standard **CLIP** mounting plates.

All **CLIP top** hinges feature "Spiral-Tech" depth adjustment which eliminates loosening and retightening the adjustment screws. When the doors are ready to be attached to the cabinet, the time-proven **CLIP** mechanism connects the hinge arm to the mounting plate, again without tools. All components are nickel-plated and have self-closing action, eliminating the need for additional hardware.

On pages **35-36**, configurations of common American cabinet widths are shown with the transition of cabinet depths that create the need for angled hinges. Because the self-closing action starts at 5° before final closed position and a built-in closing reserve of 3°, the Blum system offers a solution for all angled cabinet applications.

Step 1. On page **37** cross-reference the corner style that is needed for your particular angled application.

Step 2. Once the cabinet front angle is determined, select the row for that angle from the first column. There are five different possibilities for positive angles and two for negative angles.

Step 3. Cross-reference the angle to the style to find the hinge/plate/wedge combination and the specification number. Specifications on pages **38** through **44** are in numerical order and show all the details.

Cover caps
Mounting plates

page 31

pages 47-51



Positive angled CLIP top hinges

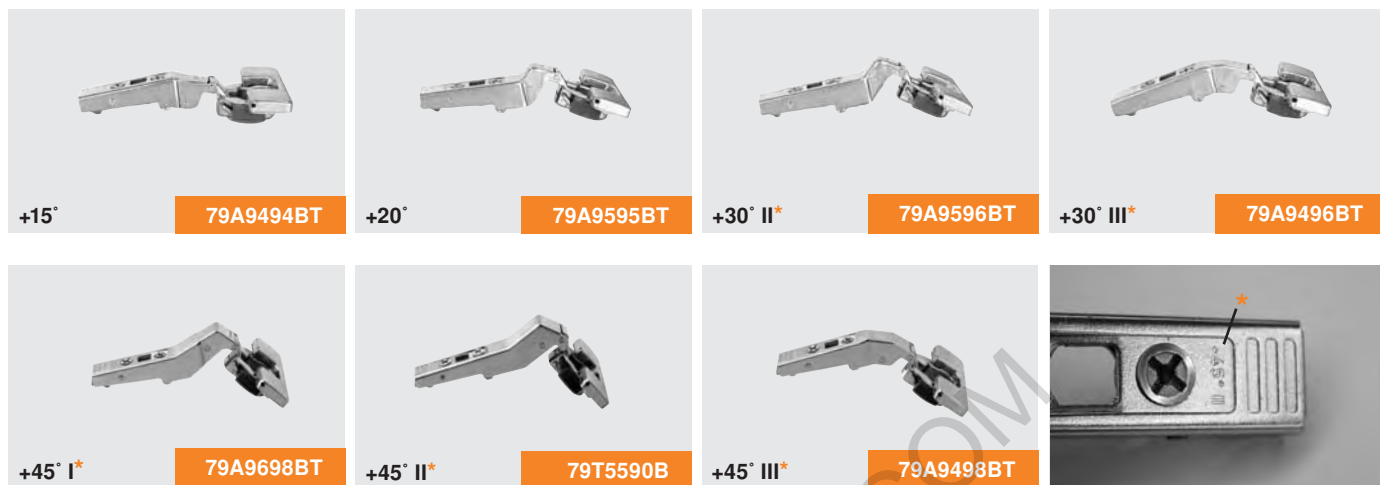

* These angled hinges are marked I, II, or III on the hinge arm for differentiation (see photo).

Negative angled CLIP top hinges

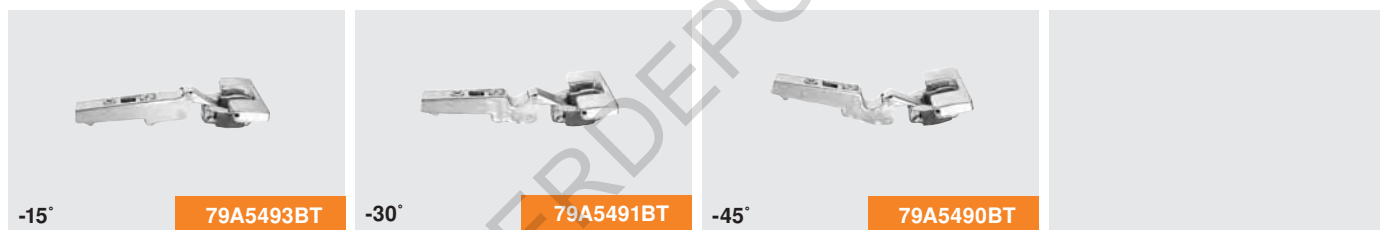

Standard CLIP top thick door hinges used in angled applications



Angled spacer wedges for positive and negative angled hinges



Angled cabinet configurations

Match desired configuration to "Angle-to-style cross-reference" chart on page 37

Angled

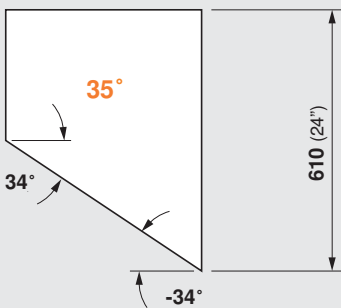
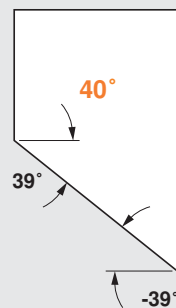
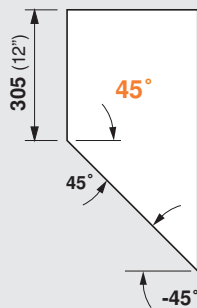
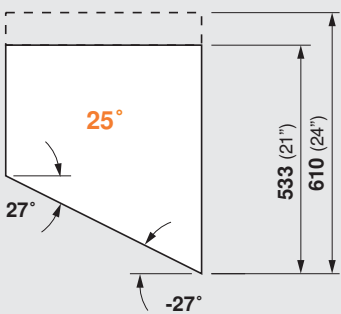
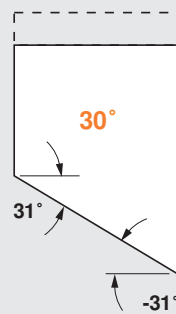
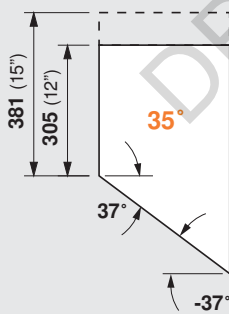
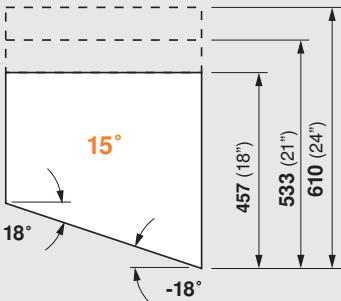
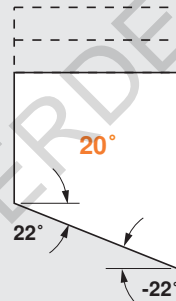
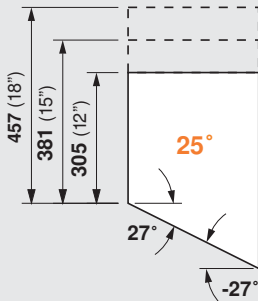
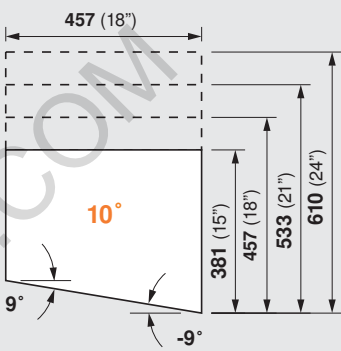
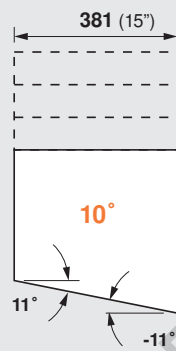
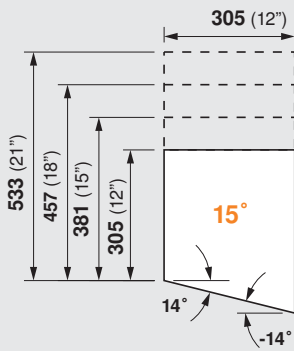
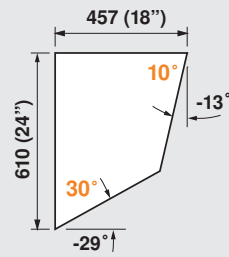
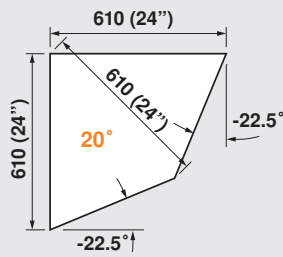
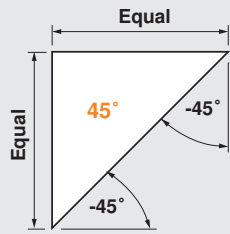



Match desired configuration to "Angle-to-style cross-reference" chart on page 37

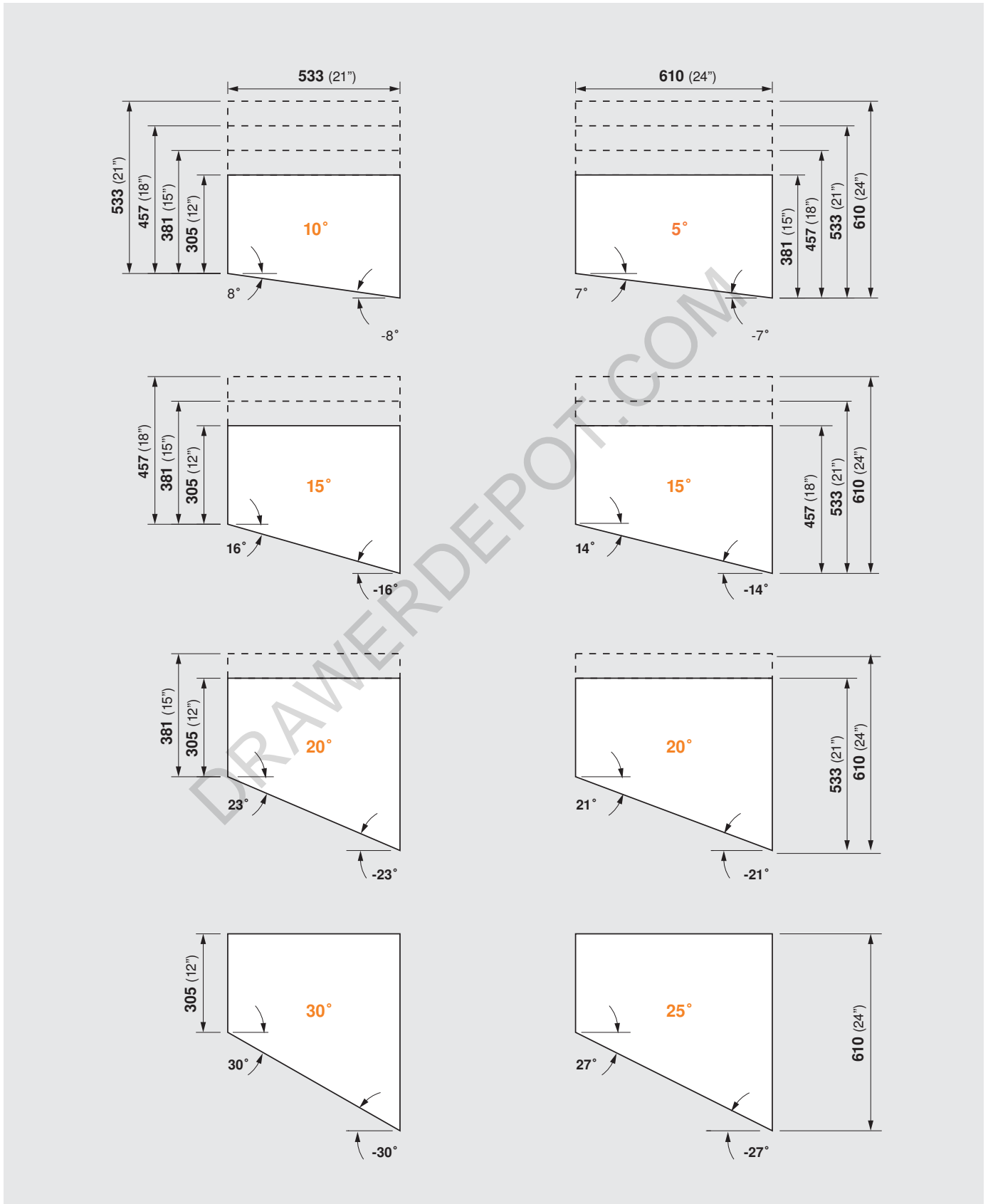

Angled



Angle-to-style cross-reference

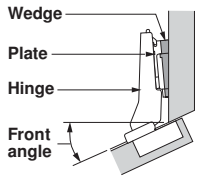

Code number	Specifications on pages 36-42	
Hinge	Clip top hinge	Part number
Plate	Clip mounting plate	Part number
Wedge	May or may not be required	Part number

Angled

Positive angles

Negative angles



Maximum overlay Partial overlay Corner merge Inset door Mitered corner Maximum overlay Inset door

Angle	1	10	19	27		42	51
5°	71T9590B	71T9590B	71T9690B	71T9790B		71T9590B	71T9690B
	173H7100	173H7100	173H7100	173H7100		173H7100	173H7100
	171A5010	171A5010	171A5070	171A5010		171A5500	171A5500
10°	79A9494BT	79A9494BT	79A9494BT	79A9494BT		79A5493BT	79A5493BT
	173H7100	173H7100	175H9190.22	175H9190.22		173H7100	175H7190
	171A5500	171A5500	171A5500	171A5500		171A5010	171A5070
15°	79A9494BT	79A9494BT	79A9595BT	79A9595BT	79A9595BT	79A5493BT	79A5493BT
	175H9160	175H9190	173H7130	175H9190	173H7100	173H7100	175H9190.22
	—	—	171A5500	171A5500	171A5500	—	—
20°	79A9494BT	79A9595BT	79A9595BT	79A9595BT	79A9595BT	79A5493BT	79A5493BT
	173H7100	173H7100	175H9190	175H9190.22	175H9160	173H7100	175H7160
	171A5070	—	—	—	—	171A5500	171A5500
25°	79A9496BT	79A9595BT	79A9596BT	79A9596BT	79A9596BT	79A5491BT	79A5491BT
	173H7100	173H7100	173H7100	175H9190.22	173H7100	173H7100	175H7190
	171A5500	171A5010	171A5500	—	171A5500	171A5040	171A5070
30°	79A9496BT	79A9596BT	79A9596BT	79A9596BT	79A9596BT	79A5491BT	
	175H9160	173H7100	175H9190	175H9190.22	173H7130	173H7130	
	—	—	—	—	—	—	
35°	79A9496BT	79A9596BT	79A9596BT	79A9596BT	79A9596BT	79A5491BT	
	173H7100	173H7100	173H7100	175H9190.22	173H7100	173H7100	
	171A5070	171A5010	171A5070	171A5010	171A5040	171A5500	
40°	79A9498BT	79A9498BT		79A9698BT		79A5490BT	
	173H7100	175H9160		175H9190		173H7100	
	171A5500	171A5500		171A5500		171A5040	
45°	79A9498BT	79T5590B	79A9698BT	79T5590B	79A9698BT	79A5490BT	79A5490BT
	175H9160	173H7100	173H7100	175H9190.22	173H7100	173H7130	175H7190
	—	—	—	—	—	—	181.6130

Maximum overlay specifications



Positive angles

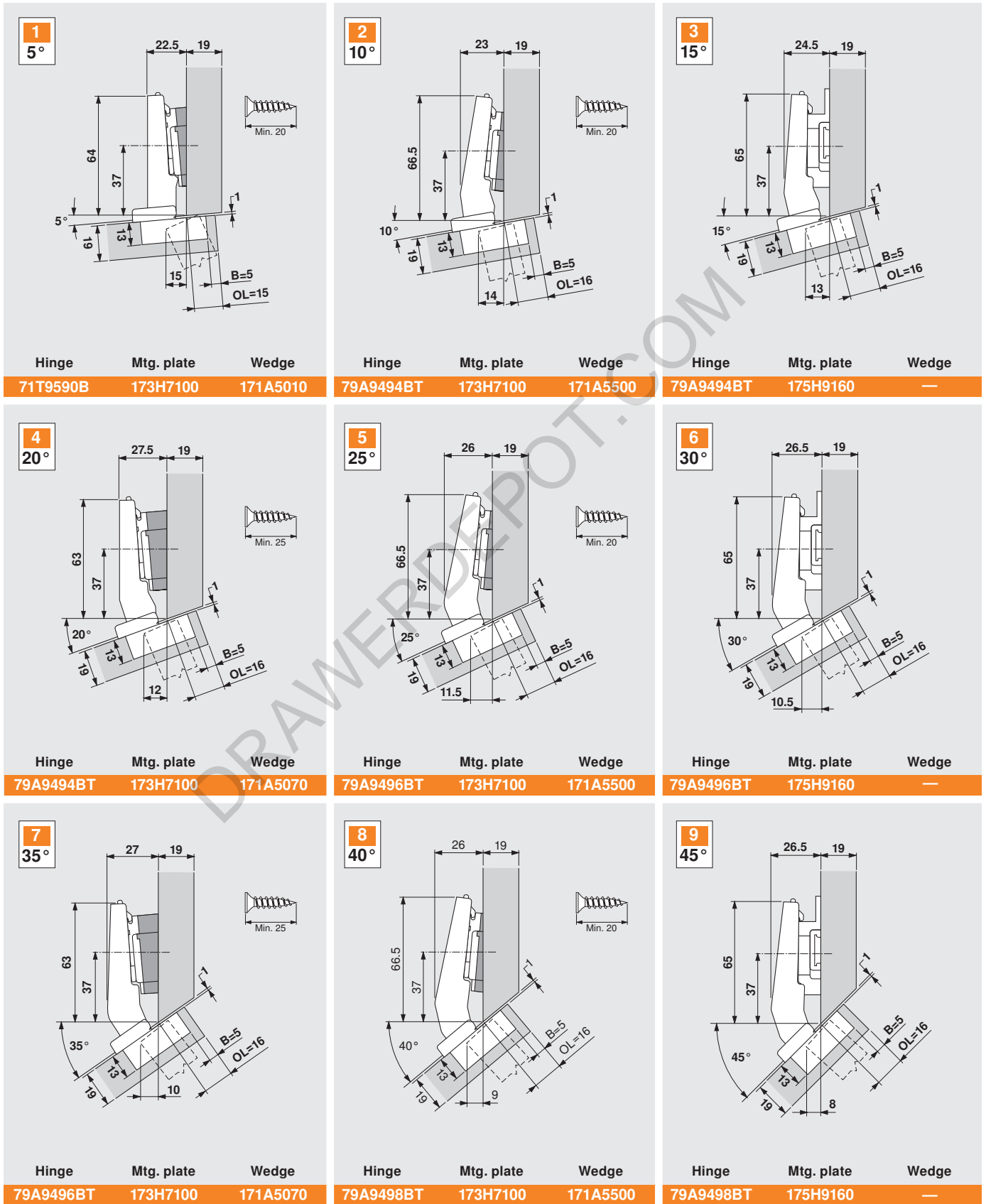

All dimensions in millimeters (inch equivalents as shown).
Subject to technical modifications without notice. © 2008

Angled

Partial overlay specifications



Positive angles

Angled

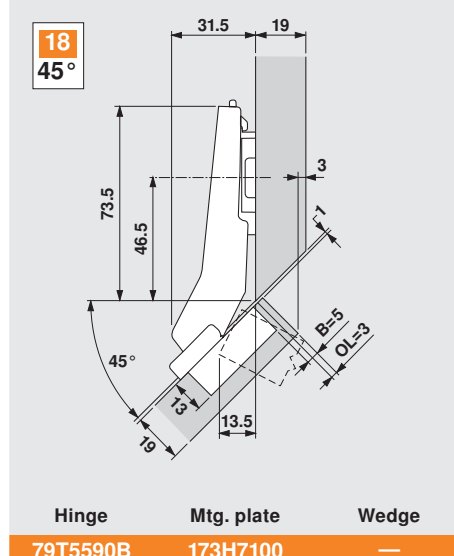
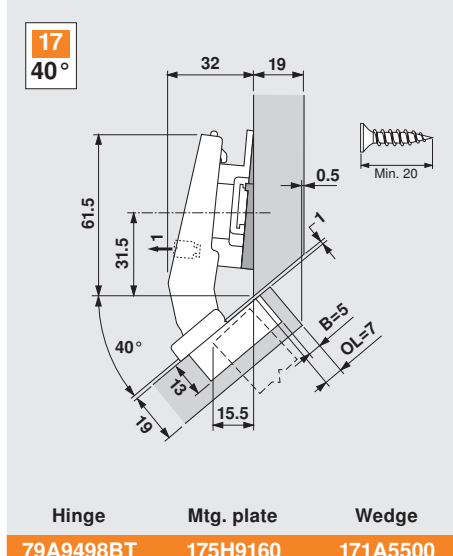
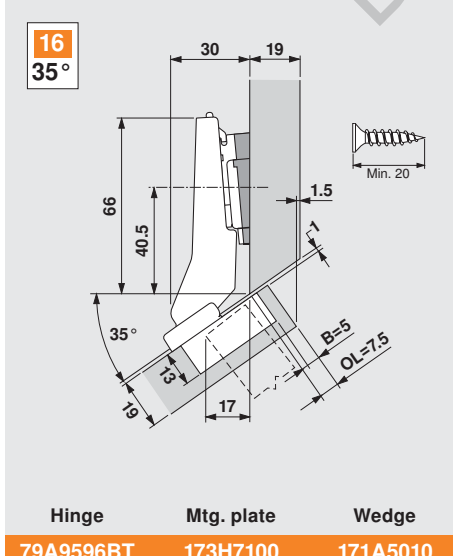
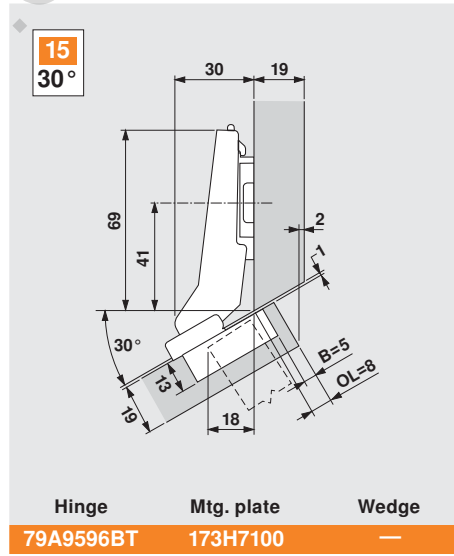
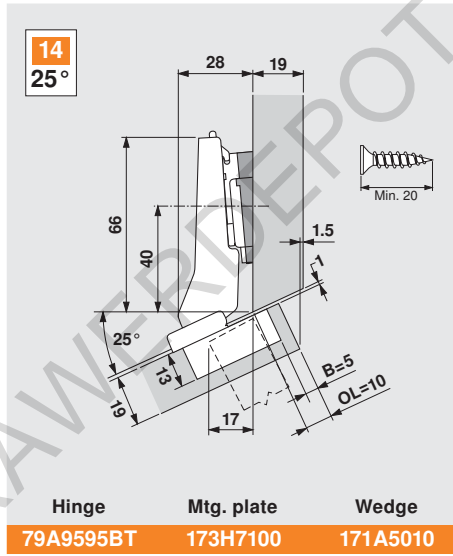
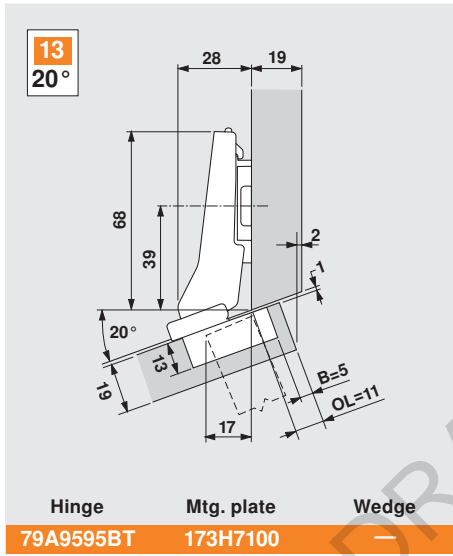
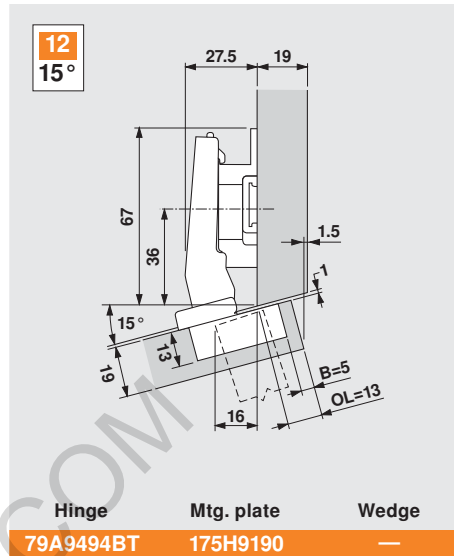
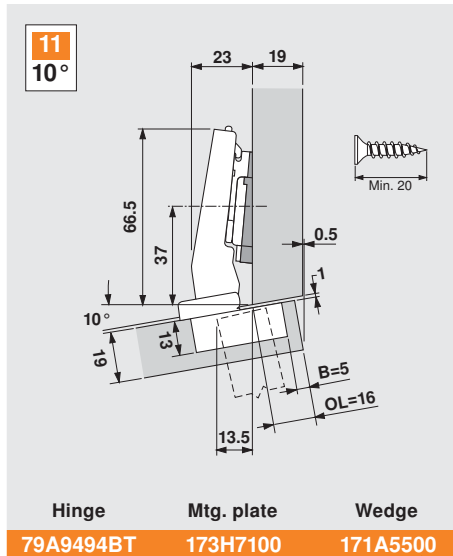
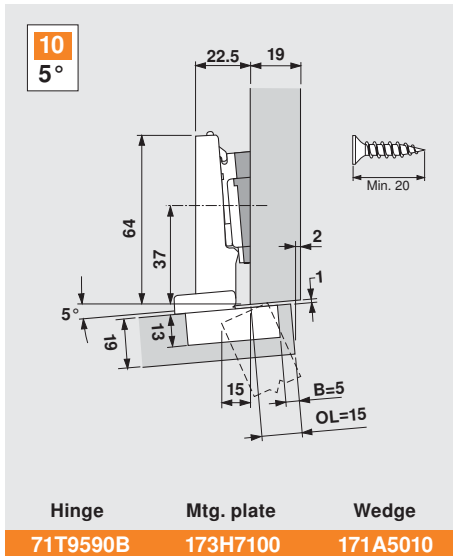

Corner merge specifications

Positive angles

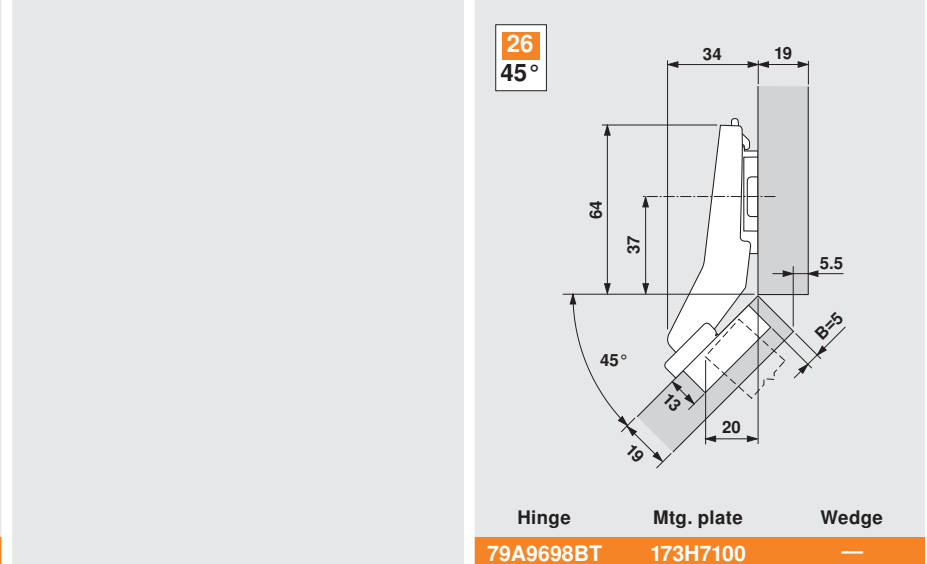
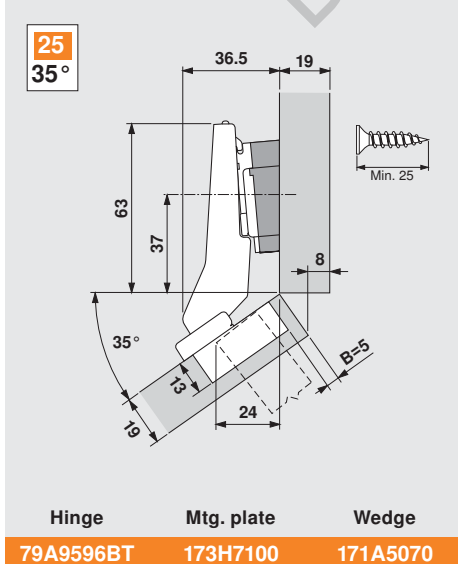
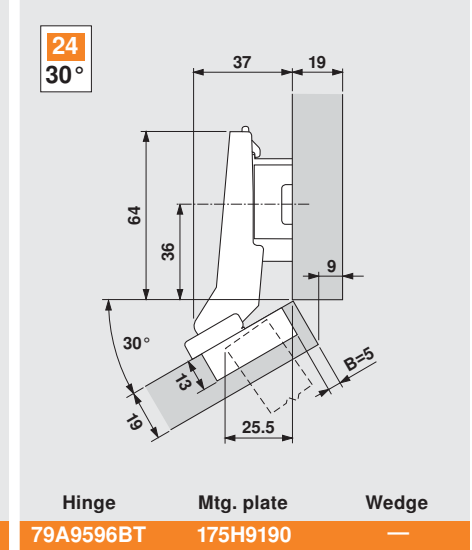
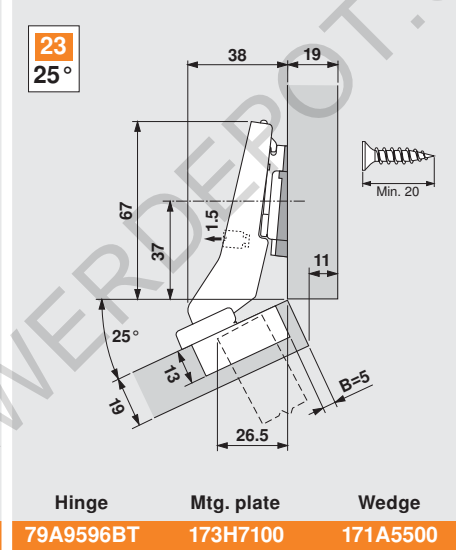
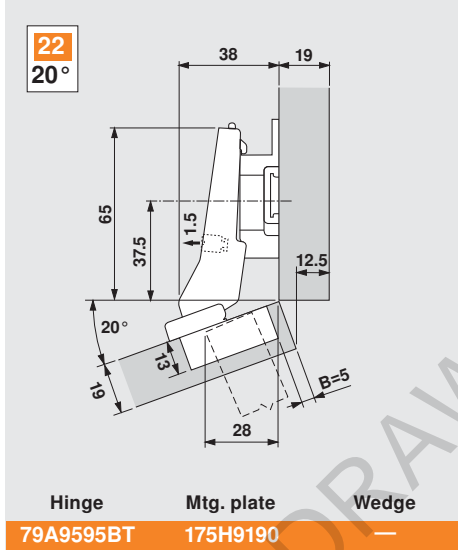
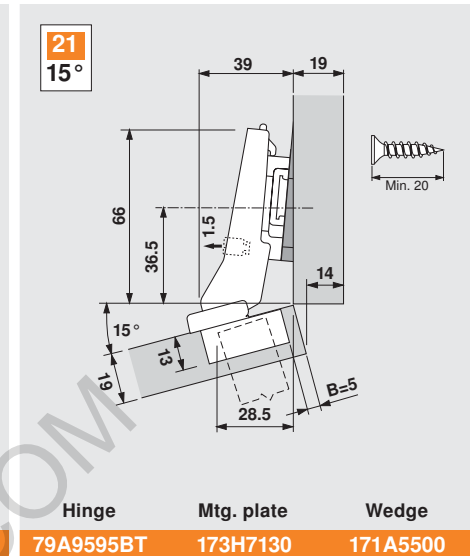
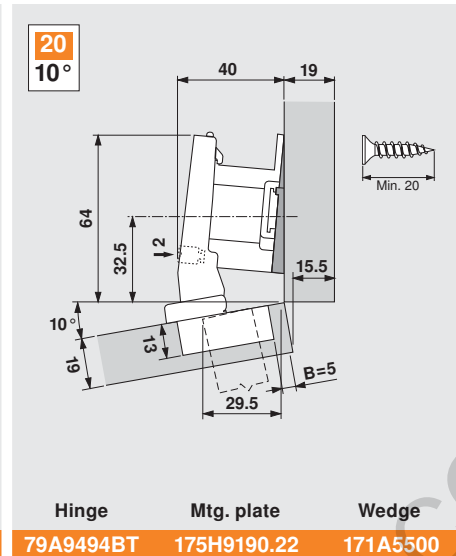
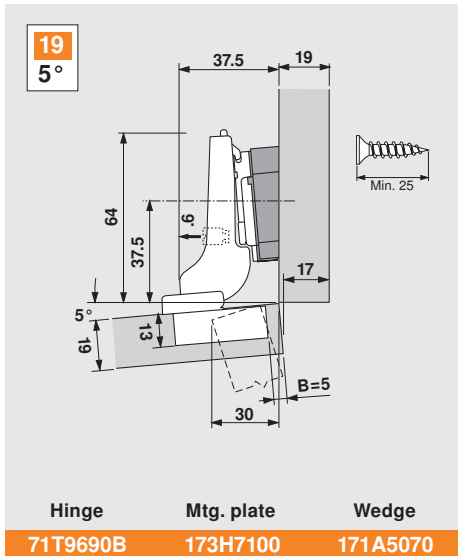

Inset door specifications



Positive angles

Angled

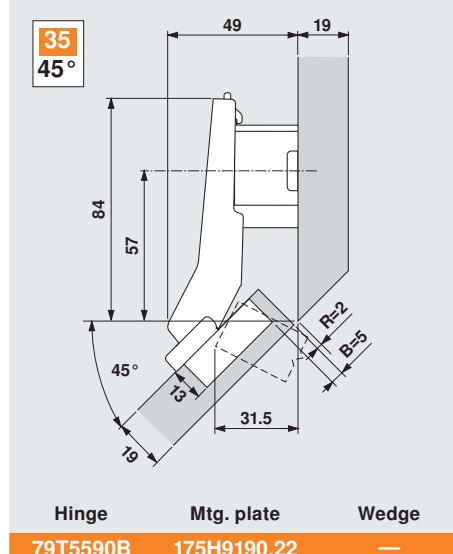
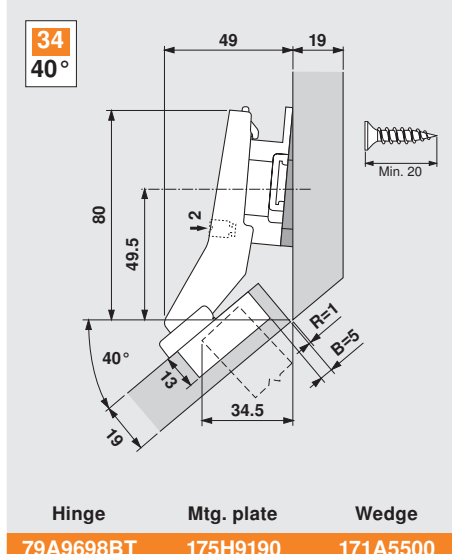
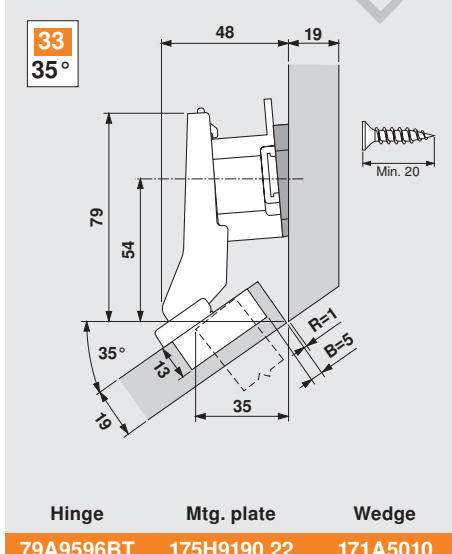
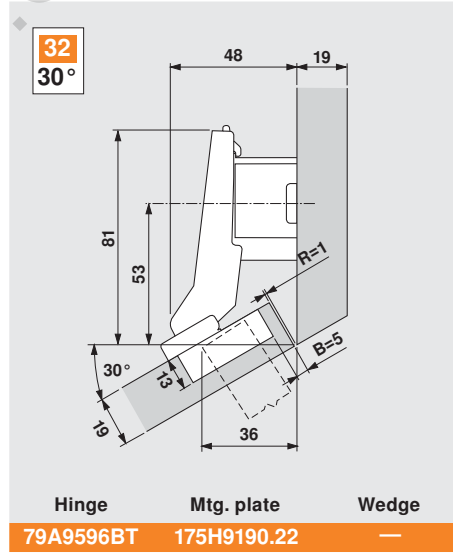
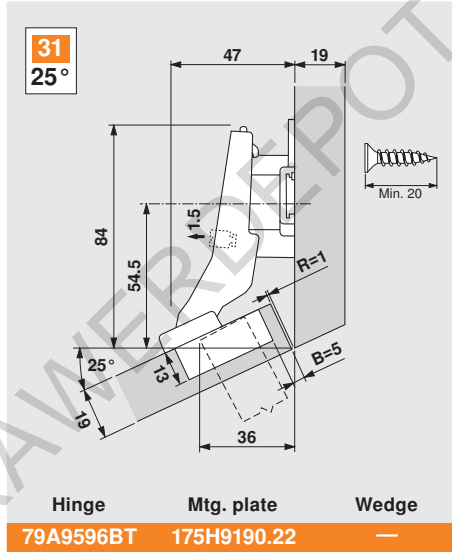
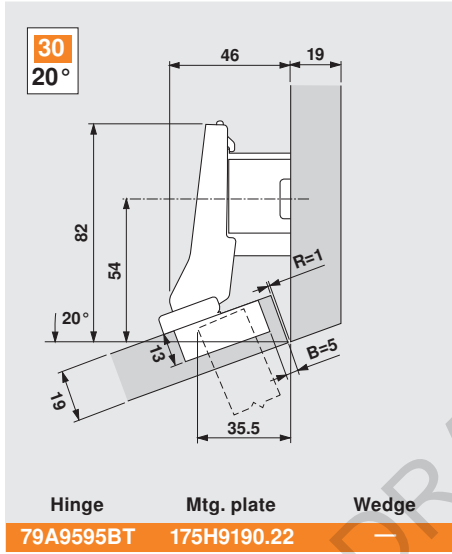
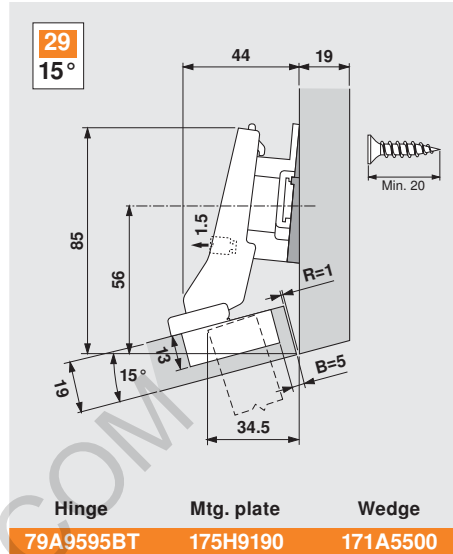
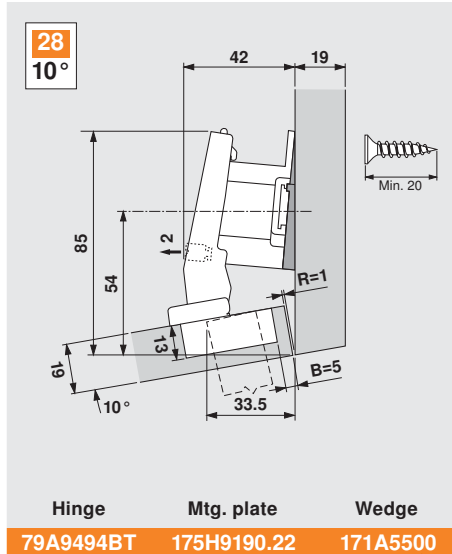
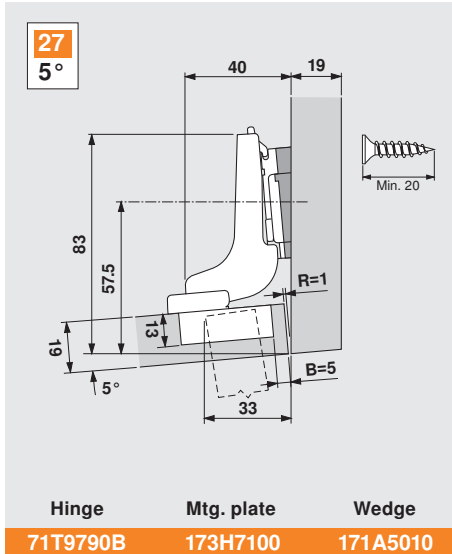

Mitered corner specifications



Positive angles

<p>36 15°</p> <p>Note: • Miter door 65° • Miter side 40° • Radius edges to fit • Trial application recommended</p> <p>Hinge Mtg. plate Wedge</p> <p>79A9595BT 173H7100 171A5500</p>	<p>37 20°</p> <p>Note: • Miter door 62° • Miter side 48° • Radius edges to fit • Trial application recommended</p> <p>Hinge Mtg. plate Wedge</p> <p>79A9595BT 175H9160 —</p>	<p>38 25°</p> <p>Note: • Miter door 70° • Miter side 45° • Radius edges to fit • Trial application recommended</p> <p>Hinge Mtg. plate Wedge</p> <p>79A9596BT 173H7100 171A5500</p>
<p>39 30°</p> <p>Note: • Miter door 70° • Miter side 50° • Radius edges to fit • Trial application recommended</p> <p>Hinge Mtg. plate Wedge</p> <p>79A9596BT 173H7130 —</p>	<p>40 35°</p> <p>Note: • Miter door 70° • Miter side 55° • Radius edges to fit • Trial application recommended</p> <p>Hinge Mtg. plate Wedge</p> <p>79A9596BT 173H7100 171A5040</p>	<p>41 45°</p> <p>Note: • Miter door 67° • Miter side 68° • Radius edges to fit • Trial application recommended</p> <p>Hinge Mtg. plate Wedge</p> <p>79A9698BT 173H7100 —</p>

Angled

Maximum overlay specifications



Negative angles

Angled

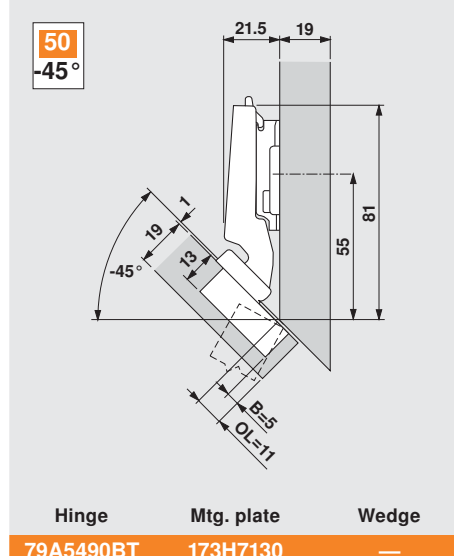
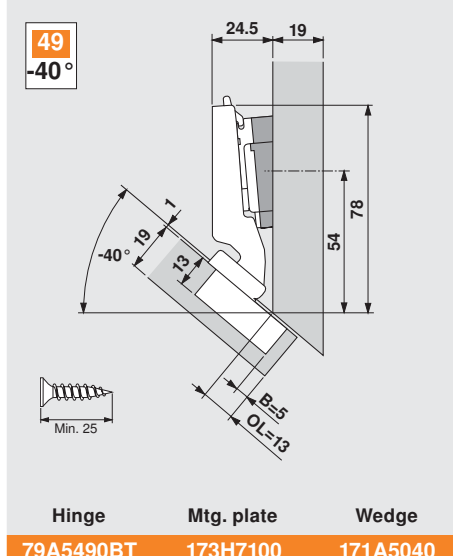
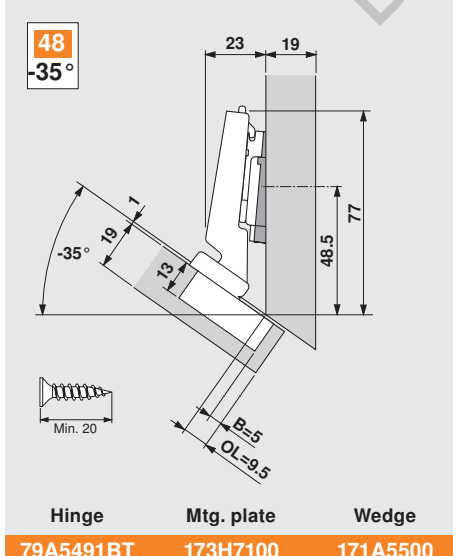
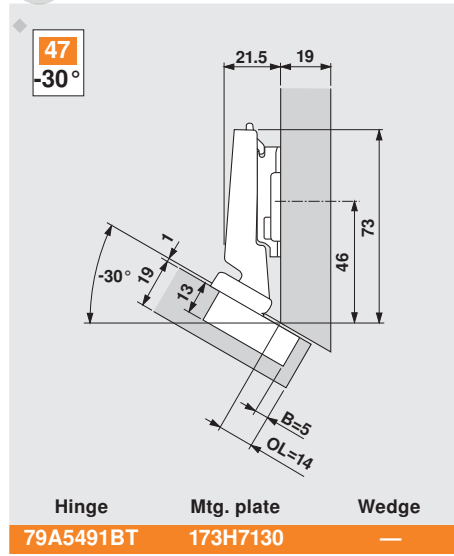
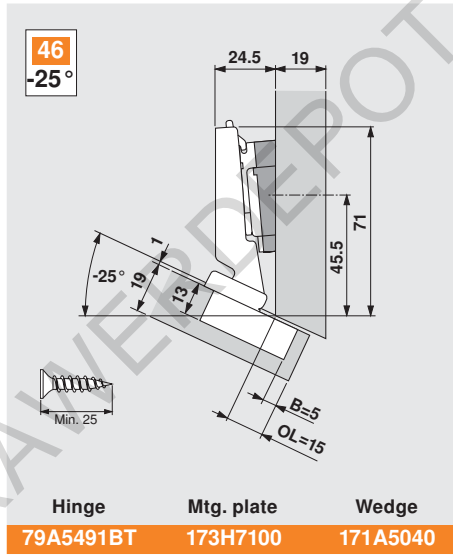
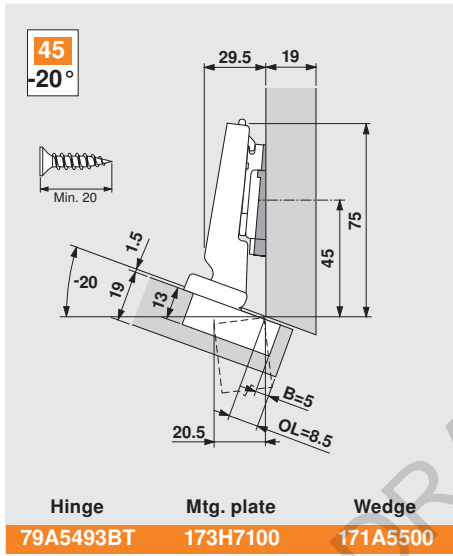
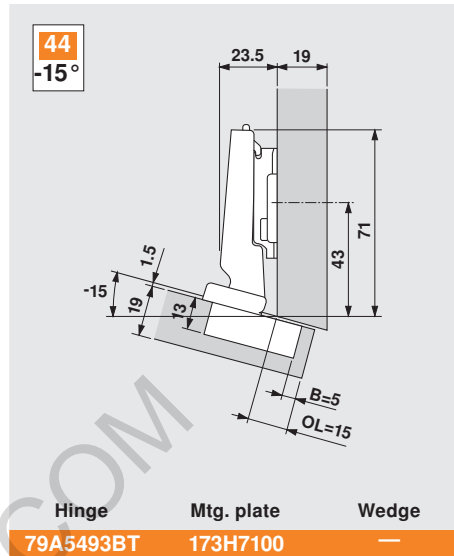
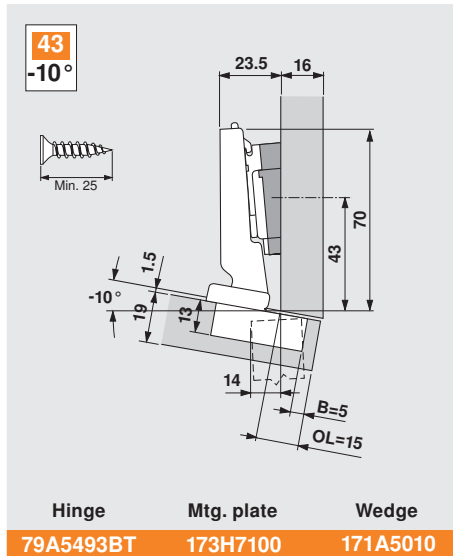
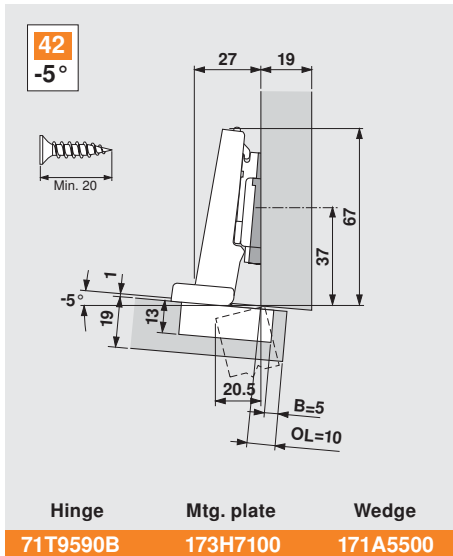

Inset door specifications



Negative angles

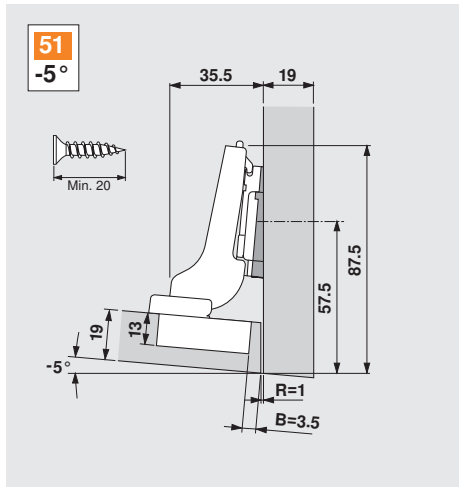

Hinge	Mtg. plate	Wedge
71T9690B	173H7100	171A5500

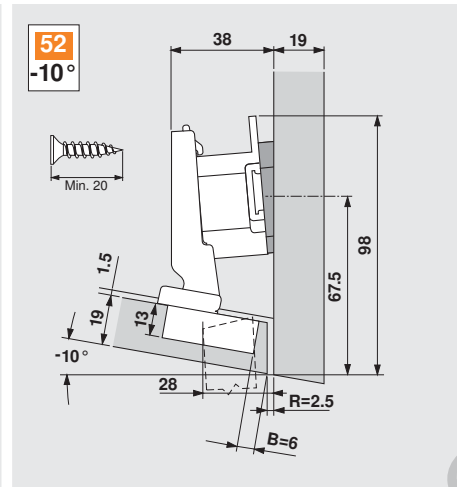

Hinge	Mtg. plate	Wedge
79A5493BT	175H7190	171A5010

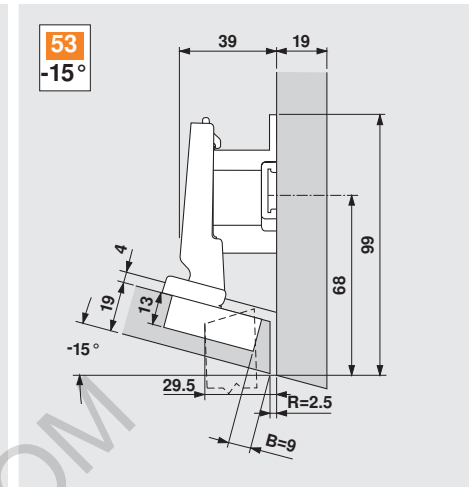

Hinge	Mtg. plate	Wedge
79A5493BT	175H9190.22	—

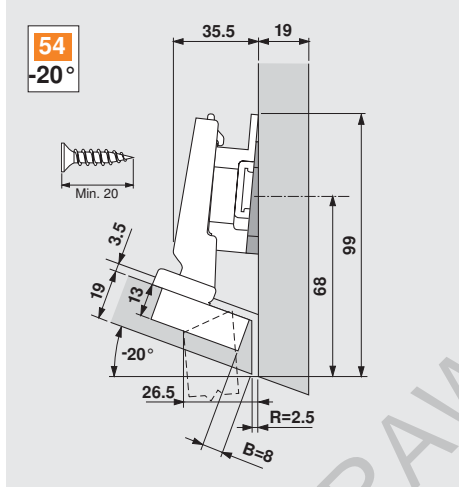

Hinge	Mtg. plate	Wedge
79A5493BT	175H9160	171A5500

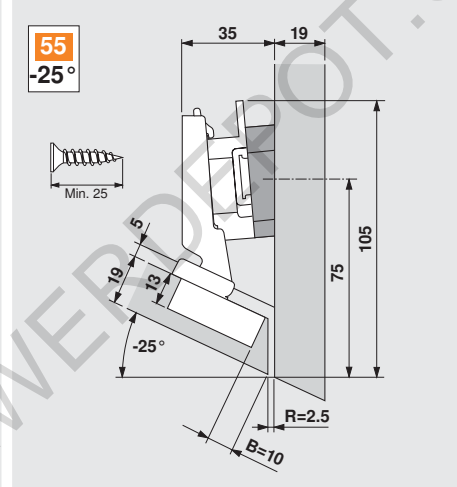

Hinge	Mtg. plate	Wedge
79A5491BT	175H7190	171A5070

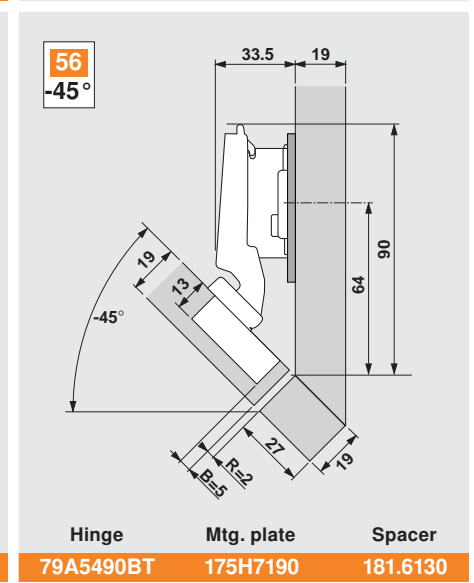
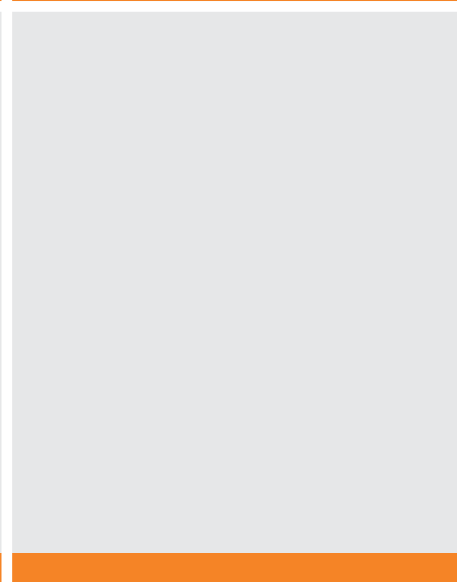
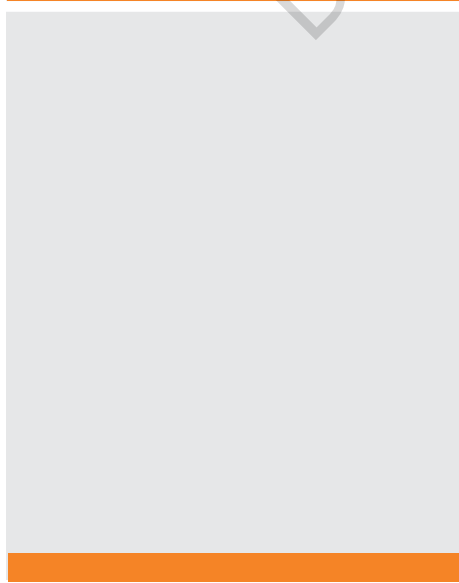
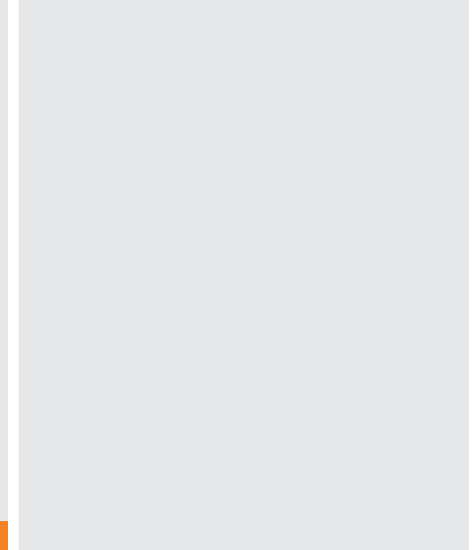

Hinge	Mtg. plate	Spacer
79A5490BT	175H7190	181.6130

All dimensions in millimeters (inch equivalents as shown).
Subject to technical modifications without notice. © 2008

Angled

DRAWERDEPOT.COM



CLIP mounting plates

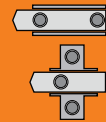

CLIP mounting plates

One piece wing mounting plate

- Steel, nickel plated
- Attached with wood screws #6 x 5/8" (606P)
- Height adjustment ± 3 mm
- *Add additional wood screw if used with wide angled hinges

Wood screws	(H) Height 0	(H) Height 3
#6 x 5/8" (606P)	173L6100	173L6130

One piece wing mounting plate

CLIP plates

- Steel, nickel plated
- Attached with pre-mounted system screws $\varnothing 5$ mm (668.1450.EH)
- Height adjustment ± 3 mm
- *Add additional wood screw if used with wide angled hinges

System screws	(H) Height 0	(H) Height 3
Pre-mounted	173L8100	173L8130

EXPANDO mounting plate

- Steel, nickel plated
- Attached with pre-mounted screws with EXPANDO dowels (618.1500)
- Height adjustment ± 2 mm
- *Add additional wood screw if used with wide angled hinges

EXPANDO dowels	(H) Height 0	(H) Height 3
Pre-mounted	174E6100.01	174E6130.01

EXPANDO mounting plate (twin application)

- Steel, nickel plated
- Attached with pre-mounted screws with EXPANDO dowels for twin application (618.1500)
- Height adjustment ± 2 mm
- *Additional wood screw required

EXPANDO dowels	(H) Height 0
Pre-mounted	174E610Z

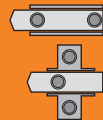

CLIP mounting plates

Cam mounting plate



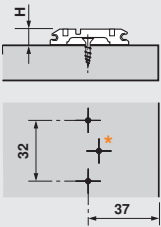

- Steel, nickel plated
- Attached with wood screws #6 x 5/8" (606P)
- Cam height adjustable ± 2 mm
- *Add additional wood screw if used with wide angled hinges

Wood screws	(H) Height 0	(H) Height 3
#6 x 5/8" (606P)	173H7100	173H7130

Cam mounting plate



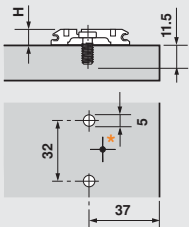

- Steel, nickel plated
- Attached with system screws (661.1450.HG)
- Cam height adjustment ± 2 mm
- *Add additional wood screw if used with wide angled hinges

Wood screws or System screws	(H) Height 0	(H) Height 3
#7 x 5/8" (707N) 661.1450.HG	173H9100	173H9130

CLIP plates

EXPANDO cam mounting plate



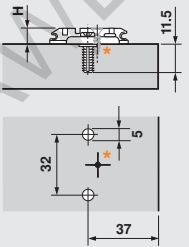

- Steel, nickel plated
- Attached with pre-mounted screws with EXPANDO dowels (618.1500)
- Cam height adjustment ± 2 mm
- *Add additional wood screw if used with wide angled hinges

EXPANDO dowels Pre-mounted	(H) Height 0	(H) Height 3
	174H7100E	174H7130E

EXPANDO cam mounting plate (twin application)



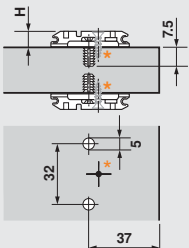

- Steel, nickel plated
- Attached with pre-mounted screws with EXPANDO dowels for twin application (618.1500)
- Cam height adjustment ± 2 mm
- *Additional wood screw required

EXPANDO dowels Pre-mounted	(H) Height 0
	174H710ZE

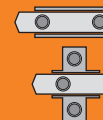

CLIP mounting plates

INSERTA cam mounting plate



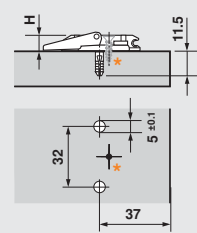

- Steel (closing lever – zinc die-cast, nickel plated)
- Tool-free assembly with self-anchoring feature
- Cam height adjustment ± 2 mm
- *Add additional wood screw if used with wide angle hinges

INSERTA dowels	(H) Height 0
Pre-mounted	174H7100I

One piece wing mounting plate



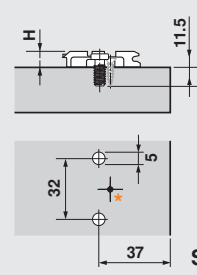

- Zinc die-cast, nickel plated
- Attached with pre-mounted system screws $\varnothing 5$ mm (668.1450.EH)
- Height adjustment ± 3 mm
- *Add additional wood screw if used with wide angle hinges

System screws	(H) Height 0	(H) Height 3	(H) Height 9
Pre-mounted	175L8100	175L8130	175L8190

Two piece wing mounting plate



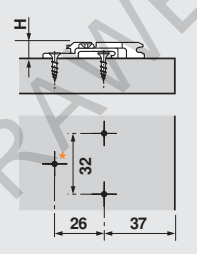

- Zinc die-cast, nickel plated
- Attached with wood screws #6 x 5/8" (606P)
- Height adjustment ± 2 mm
- *Add additional wood screw if used with wide angled hinges

Wood screws	(H) Height 0	(H) Height 3	(H) Height 9
#6 x 5/8" (606P)	175H7100	175H7130	175H7190

Two piece wing mounting plate



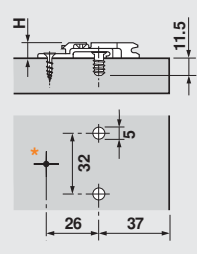

- Zinc die-cast, nickel plated
- Attached with system screws $\varnothing 5$ mm (661.1150.HG)
- Height adjustment ± 2 mm
- *Add additional wood screw if used with wide angled hinges

Wood screws or System screws	(H) Height 0	(H) Height 3	(H) Height 6	(H) Height 9	(H) Height 18
#7 x 5/8" (707N) 661.1150.HG	175H9100	175H9130	175H9160	175H9190	175H9190.22

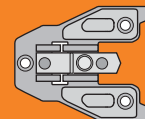

CLIP in-line mounting and face frame adapter plates

Screw-on cam in-line mounting plate

- Zinc die-cast, nickel plated
- Screw-on assembly with included screws (629.1700)
- Cam height adjustment ± 2 mm
- Use of the QUICKFIX (page 77) or mounting plate template (page 76) recommended for proper installation

Wood screws 629.1700 (included)	(H) Height 0 175H5100.05
---	------------------------------------

Press-in cam in-line mounting plate

- Zinc die-cast, nickel plated
- Press-in assembly with pre-attached dowels
- Assembly with #50 insertion ram or knock-in tool (page 85)
- Cam height adjustment ± 2 mm
- Use of the QUICKFIX (page 77) or mounting plate template (page 76) recommended for proper installation

Press-in Pre-mounted dowels	(H) Height 0 177H5100	(H) Height 3 177H5130
---------------------------------------	---------------------------------	---------------------------------

CLIP plates

Face frame cam adapter plate – center mount

- Steel, zinc die-cast and nickel plated
- Center mount 9.5 (3/8")
- Cam height adjustment ± 2 mm
- Use of the PlateMate recommended (see page 78)

Wood screws #7 x 3/4" (7074N)	(H) Height 0 175H6000	(H) Height 3 175H6030	(H) Height 4.5 175H6040	(H) Height 6 175H6060
---	---------------------------------	---------------------------------	-----------------------------------	---------------------------------

* 175H6000 not for use with INSERTA hinges (use 175H6600)

Face frame cam adapter plate – off-center mount

- Steel, zinc die-cast and nickel plated
- For use with INSERTA hinge cups
- Off-center mount 12.5 (1/2")
- Cam height adjustment ± 2 mm
- Use of the PlateMate recommended (see page 78)

Wood screws #7 x 3/4" (7074N)	(H) Height 0 175H6600
---	---------------------------------

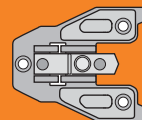

CLIP face frame adapter plates

Face frame adapter plate – off-center mount

- Zinc die-cast, nickel plated
- Off-center mount **12.5** (1/2")
- Height adjustment ± 2 mm
- Use of the PlateMate recommended (see page 78)

Wood screws	(H) Height 0	(H) Height 3	(H) Height 6
#7 x 3/4" (7074N)	175L6600.22	175L6630.22	175L6660.22

Face frame adapter plate – center mount

- Zinc die-cast, nickel plated
- Center mount **9** (3/8")
- Height adjustment ± 2 mm
- Use of the PlateMate recommended (see page 78)

Wood screws	(H) Height 3
#7 x 3/4" (7074N)	175L6030.21

Inset face frame cam adapter plate

- Use with half-cranked hinges only
- Zinc die-cast, nickel plated
- Attached with truss head screws #8 x 3/4" (834TH)
- Can be used on frames with applied bead molding
- Cam height adjustment ± 2 mm
- 170° hinges not recommended
- **Use of the PlateMate required** (see page 78)

Wood screws	(H) Height 3
#8 x 3/4" truss head (834TH)	175H5030.21

Face frame mounting plate with flange

- Recommended when using the 170° and 0 protrusion hinges on face frame cabinets
- Zinc die-cast, nickel plated
- Off-center mount **12.5** (1/2")
- Height adjustment ± 2 mm
- Use of the PlateMate recommended (see page 78)
- Replaces 175L6600.23

Wood screws	(H) Height 0
#7 x 3/4" (707N)	175L6600.24

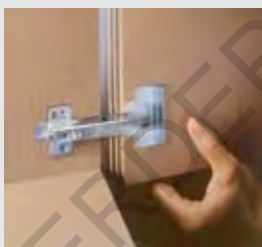

MODUL hinges



MODUL general specifications

Mounting plate-to-cabinet

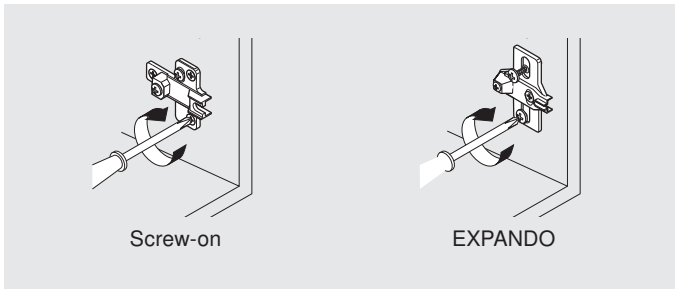

Hinge-to-door attachment

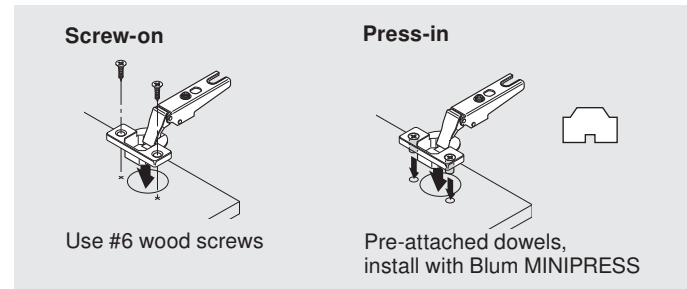

Blum boring pattern

C Cup centerpoint					
20.5	21.5	22.5	23.5	24.5	25.5
13/16"	27/32"	7/8"	15/16"	31/32"	1"
3	4	5	6	7*	8*
B Bore distance					

* only for use with select Blum hinges

Cup centerpoint is the MINIPRESS or MINIDRILL fence depth position.

Door-to-cabinet attachment

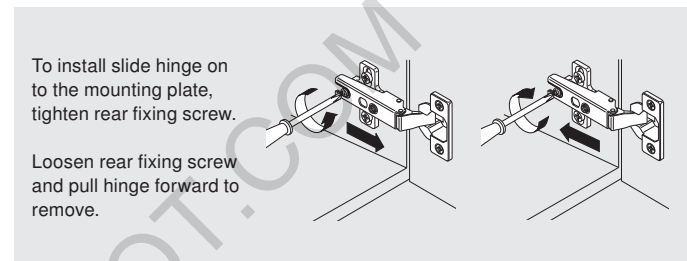

Three-dimensional adjustment

Side adjustment

Turn front screw to increase or decrease door overlay.
Range = ± 2 mm

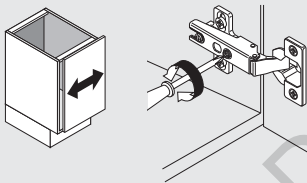

Depth adjustment

Loosen back screw. Adjust door to position and tighten screw.
Range = ± 2 mm

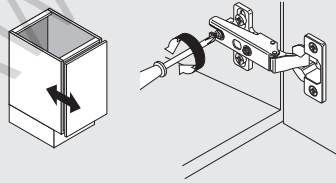

Height adjustment

Loosen screw(s) on the mounting plate. Adjust door to position and tighten screws.
Range = ± 3 mm

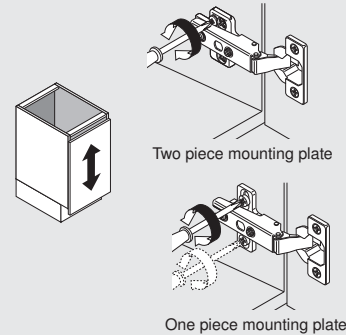

Hinge dimension abbreviations

B = Boring distance
H = Mounting plate height
OL = Door overlay
P = Door protrusion (at max opening)

R = Reveal
S = Hinge arm protrusion
T = Door thickness
W = Side panel width
X = Fixed cup distance

Minimum reveal

A minimum reveal per door is required to keep the door from binding and varies depending on door thickness (see Minimum reveal table for each hinge). **Minimum reveal based on outside door edge with radius of 1 (1/32").**

Hinges per door

X = Door height
Y = Number of hinges

This chart can serve as a guide for determining the number of hinges per door. Note that door weight can also determine the number of hinges required.

Door Height (X)	Number of Hinges (Y)	Weight Range (lb.)
20"	2	15 lb.
40"	3	15-30 lb.
60"	4	30-45 lb.
80"	5	45-60 lb.

* The distance between the two hinges must be greater than the width of the door for maximum stability.

MODUL 100° hinges



Features

- 100° opening angle
- All metal hinge, nickel plated
- Three-dimensional adjustment
- Slide-on hinge arm

Cover caps
Mounting plates

page 59
pages 57-58

Minimum Reveal

Minimum reveal table							
0.5	0.9	1.1	1.4	2.3	3.6	5.2	3
0.5	0.8	1.0	1.3	2.0	3.3	4.8	4
0.4	0.8	1.0	1.2	1.8	3.0	4.4	5
0.4	0.8	0.9	1.1	1.7	2.8	4.1	6
16	18	19	20	22	24	26	B
T Door thickness							Bore

Cross-reference the door thickness and bore distance to assure that doors won't bind when opened.

See back cover fold out for more specifications →

Frame cabinet applications

Overlay door

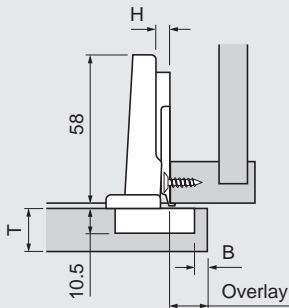

Panel cabinet applications

Overlay door

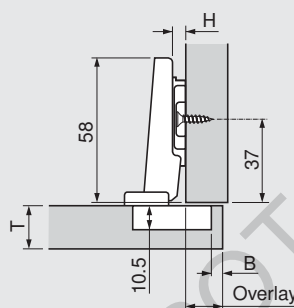

Straight-arm hinges

	Self close	Free swing
Screw-on	91M2550	90M2550
Press-in	91M2580	90M2580

Overlay table						
0	14	15	16	17	9	20
3	11	12	13	14	12	23
6	8	9	10	11	15	26
9	5	6	7	8	18	29
H	3	4	5	6	P	S
Plate	B Bore distance				Clearances	

11 fixed distance

NOTE: 9 plate only available for panel cabinets

Partial overlay door

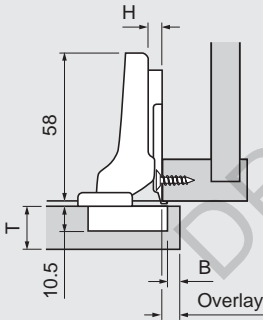

Twin overlay doors

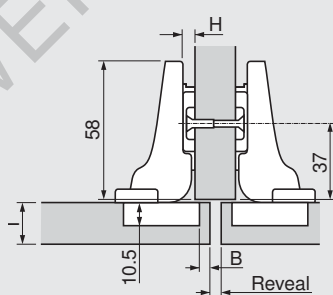

Half-cranked hinges (9.5 mm)

	Self close
Screw-on	91M2650
Press-in	91M2680

Overlay table						Partial overlay	
0	4.5	5.5	6.5	7.5	18.5	30	
H	3	4	5	6	P	S	
Plate	B Bore distance				Clearances		

1.5 fixed distance

Reveal table						Twin overlay	
0	7	5	3	1	16	18.5	30
	10	8	6	4	19		
	13	11	9	7	22		
H	3	4	5	6	W	P	S
Plate	B Bore distance				Panel	Clearances	

Full-cranked hinges (18 mm)

	Self close
Screw-on	91M2750
Press-in	91M2780

Reveal table						
0	4	3	2	1	27	38
H	3	4	5	6	P	S
Plate	B Bore distance				Clearances	

- 7 fixed distance

MODUL

For more information on using this section see page 5.
All dimensions in millimeters (inch equivalents as shown).
Subject to technical modifications without notice. © 2008

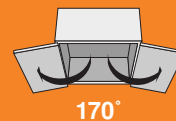

MODUL 170° hinges



Features

- 170° opening angle
- All metal hinge, nickel plated
- Three-dimensional adjustment
- Slide-on hinge arm

Cover caps
Mounting plates

page 59
pages 57-58

Minimum Reveal

Minimum reveal table							
0	0	0	0	0.2	2.2	4.2	3
0	0	0	0	0	1.4	3.8	4
0	0	0	0	0	.9	2.7	5
0	0	0	0	0	0	2.2	6
0	0	0	0	0	0	1.7	7
0	0	0	0	0	0	1.3	8
16	18	19	20	22	24	26	B
T Door thickness							Bore

Cross-reference the door thickness and bore distance to assure that doors won't bind when opened.

Frame cabinet applications

Overlay door

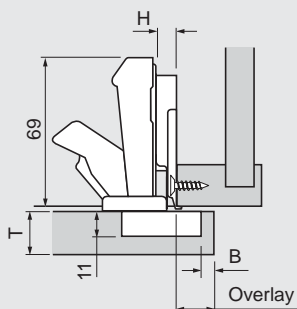

Panel cabinet applications

Overlay door

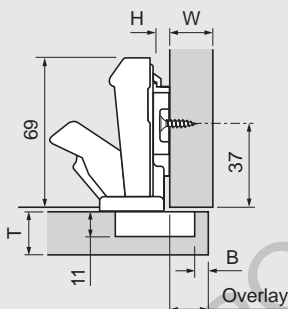

See back cover fold out for more specifications →

Straight-arm hinges

	Self close
Screw-on	91A6550
Press-in	91A6580

Overlay table									
0	14	15	16	17	18	19	1.5	65	
3	11	12	13	14	15	16	4.5	68	
6	8	9	10	11	12	13	7.5	71	
9	5	6	7	8	9	10	10.5	74	
H Plate	3	4	5	6	7	8	P	S	
	B Bore distance						Clearances		

11 fixed distance

NOTE: 9 plate only available for panel cabinets

Half-cranked hinges (9.5 mm)

	Self close
Screw-on	91A6650
Press-in	91A6680

Overlay table								Partial overlay	
0	4.5	5.5	6.5	7.5	8.5	9.5	11	75	
H Plate	3	4	5	6	7	8	P	S	
	B Bore distance						Clearances		

1.5 fixed distance

Reveal table							Twin overlay		
0	7	5	3	1	-	-	16		
	10	8	6	4	2	0	19	11	75
	13	11	9	7	5	3	22		
H Plate	3	4	5	6	7	8	W Panel	P	S
	B Bore distance						Clearances		

Half-cranked hinges (9.5 mm)

	Self close
Screw-on	91A6650
Press-in	91A6680

Reveal table								
9	4.5	3.5	2.5	1.5	0.5	-	20	84
H Plate	3	4	5	6	7	8	P	S
	B Bore distance						Clearances	

-7.5 fixed distance

Inset door

Use half-cranked hinge Any 9mm plate

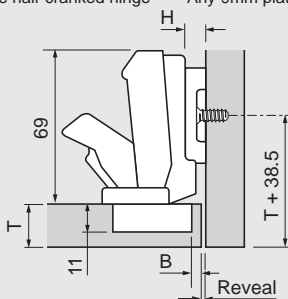

MODUL



DRAWERDEPOT.COM

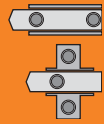

MODUL mounting plates

One piece wing mounting plate

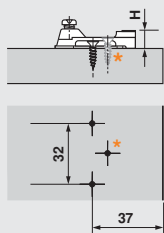
- Steel, nickel plated
- Attached with wood screws #6 x 16 mm (606P)
- Height adjustment ± 3 mm
- *Add additional wood screw if used with wide angle hinges

Wood screws	(H) Height 0
#6 x 5/8" (606P)	193L6100

One piece wing mounting plate

- Steel, nickel plated
- Attached with pre-mounted system screws $\varnothing 5$ mm (668.1450.EH)
- Height adjustment ± 3 mm
- *Add additional wood screw if used with wide angled hinges

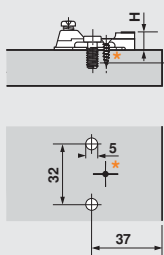
System screws	(H) Height 0
Pre-mounted	193L8100

Two piece mounting plate



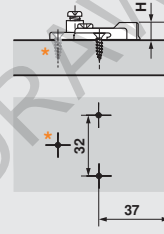

- Zinc die-cast, nickel plated
- Attached with #6 wood screw (606P)
- Height adjustment ± 2 mm
- *Add additional wood screw if used with wide angled hinges

Wood screws	(H) Height 0	(H) Height 9
#6 x 5/8" (606P)	195H7100	195H7190

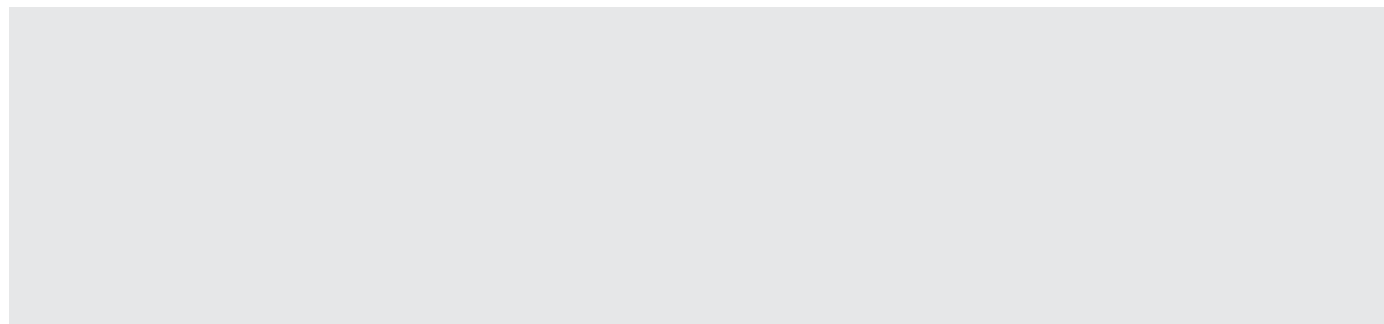
MODUL

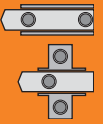



MODUL mounting plates

Two piece wing mounting plate

- Zinc die-cast, nickel plated
- Attached with system screws Ø6 x 14.5 mm (661.1450)
- Height adjustment ±2 mm
- *Add additional wood screw if used with wide angle hinges

Wood screw or System screws	(H) Height 0
#7 x 5/8" (707N) 661.1450.HG	195H9100

Face frame adapter plate

- Zinc die-cast, nickel plated
- Attached with #7 wood screws (7074N)
- Height adjustment ±2 mm
- Use of the PlateMate recommended for proper installation

Wood screws	(H) Height 0	(H) Height 6
#7 x 3/4" (7074N)	198.6600.22	198.6660.22

Recessed frame adapter plate

- Zinc die-cast, nickel plated
- Attached with #6 wood screws (606P)
- Height and side adjustment ±2 mm
- For overlays of 24 mm (15/16") to 27 mm (1-1/16")

Wood screw	(H) Height 0
#6 x 5/8" (606P)	199.0100.02



MODUL cover caps

Nylon (black or white)



MODUL cover caps

MODUL 100° hinges

MODUL 170° hinges

MODUL Blind corner hinges

	Nylon
Straight-arm	90M2103
Cranked-arm	94M3203
	80.6107
Straight-arm	90M2103

NOTE: Custom logo available in nylon (black or white). Consult your Blum representative for minimum quantities and lead times on custom logos.

MODUL

DRAWERDEPOT.COM

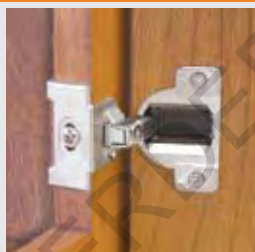

COMPACT hinges

DRAWERDEPOT.COM



Program overview - **COMPACT** hinges

Partial overlay



COMPACT 38N

- Wrap around and edge mount
- Cam depth and side adjustable
- Height adjustable

page 66



COMPACT 33

- Edge mount
- Height and side adjustable
- 2-piece zinc die-cast

page 69 - 70



COMPACT 38.

- Wrap around and edge mount
- Height adjustable

page 71

Cover caps

page 72

Full overlay



COMPACT 38/39C

- Wrap around mount
- Cam depth and side adjustable
- Height adjustable

pages 67 - 68

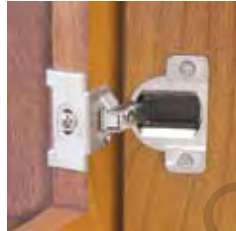

COMPACT 33

- Edge and face mount
- Height and side adjustable
- 2-piece zinc die-cast

page 69 - 70

DRAWERDEPOT.COM

Using this section - COMPACT hinges

COMPACT 38/39 - one piece hinges

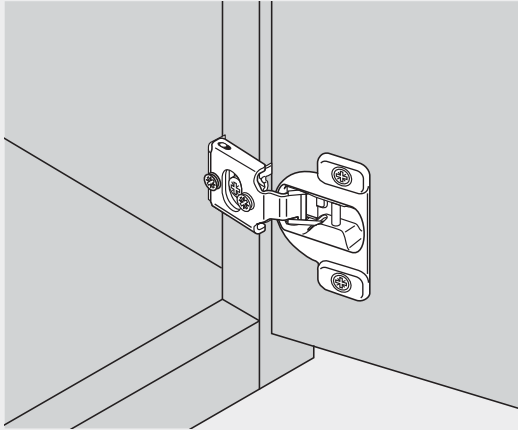

COMPACT 33 - two piece hinges

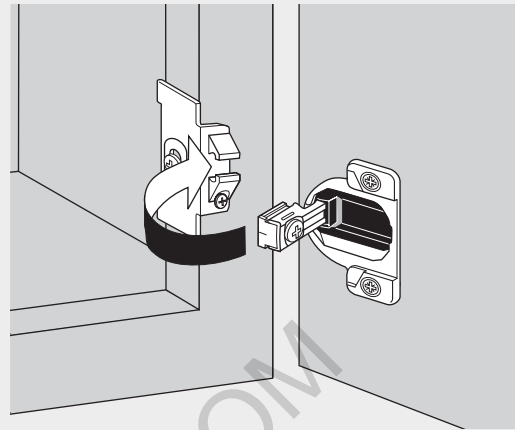

Step 1: Choose the insertion type

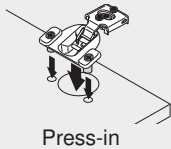
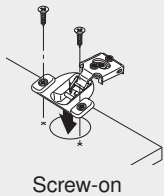

Step 1: Choose the insertion type

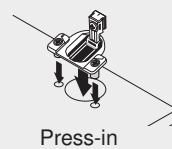
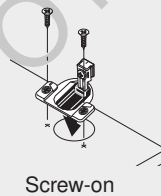

Step 2: Choose the overlay

	7/16"	Self close 1/2"
Screw-on	38N355C.07	38N355C.08
Press-in	38N358C.07	38N358C.08

Ram needed for use with MINIPRESS

Step 2: Choose the overlay by the mounting plate

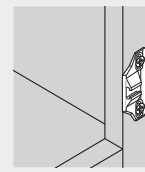
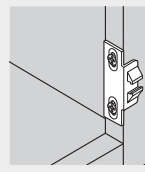

Step 3: Check minimum reveal

All minimum reveal tables are based on square edge doors. A radius or profile door will reduce the minimum reveal. Trial recommended.

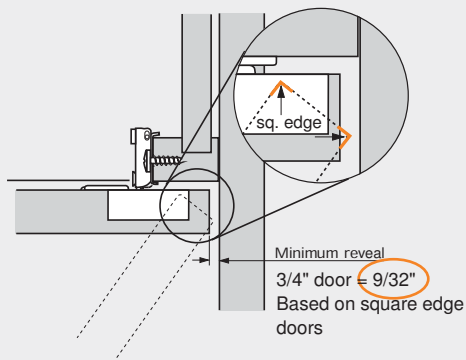

Step 3: Check minimum reveal

All minimum reveal tables are based on square edge doors. A radius or profile door will reduce the minimum reveal. Trial recommended.

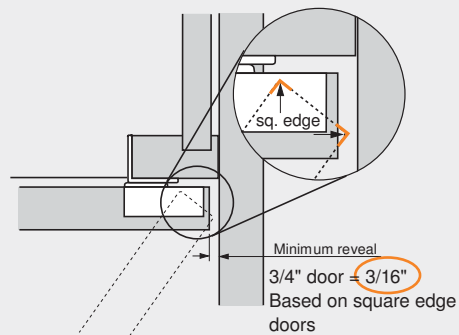

COMPACT



COMPACT 38N hinges



Features

- Steel, nickel plated
- 105° opening angle
- One piece assembly
- Wrap around or edge mount
- 7/16" cup depth
- ±1/8" height adjustment
- ±1/16" side adjustment
- +3/32" -1/32" cam depth adjustment

Minimum reveal

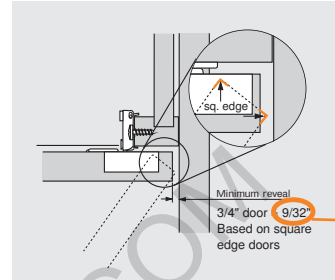

General specs & installation
Cover caps

page 65
page 72

Step 1

Step 3

Overlay application

Wrap around	3/8"	7/16"	1/2"	5/8"	3/4"
Screw-on	38N355C.06	38N355C.07	38N355C.08	38N355C.10	38N355C.12
Press-in	38N358C.06	38N358C.07	38N358C.08	38N358C.10	38N358C.12
Edge mount			1/2"		
Screw-on			38N355CE08		
Press-in			38N358CE08		

Step 2

Attachment

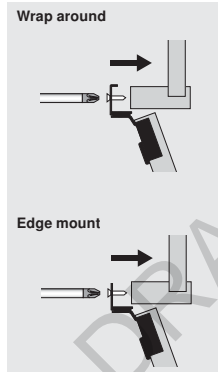

Adjustment

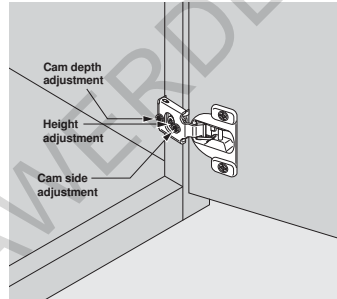

Dimensions

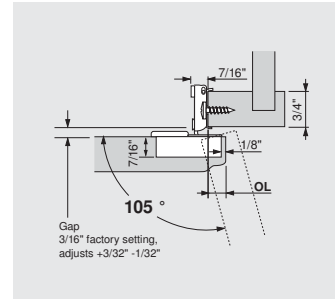

Wood screws

- #10x3/4" pilot bore **1034N**
- #8 x 3/4" self-drilling **834TH**

Boring pattern

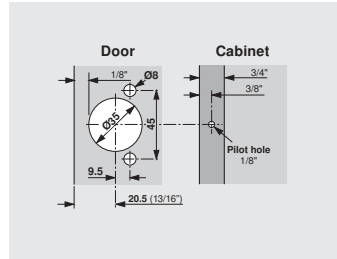

Door protrusion

OL	P
3/8"	1/4"
7/16"	3/16"
1/2"	1/8"
5/8"	0
3/4"	0

OL = Door overlay
P = Door Protrusion

Dimensions in inches. Metric where shown.
Subject to technical modifications without notice. © 2007





COMPACT general specifications

Mounting plate attachment

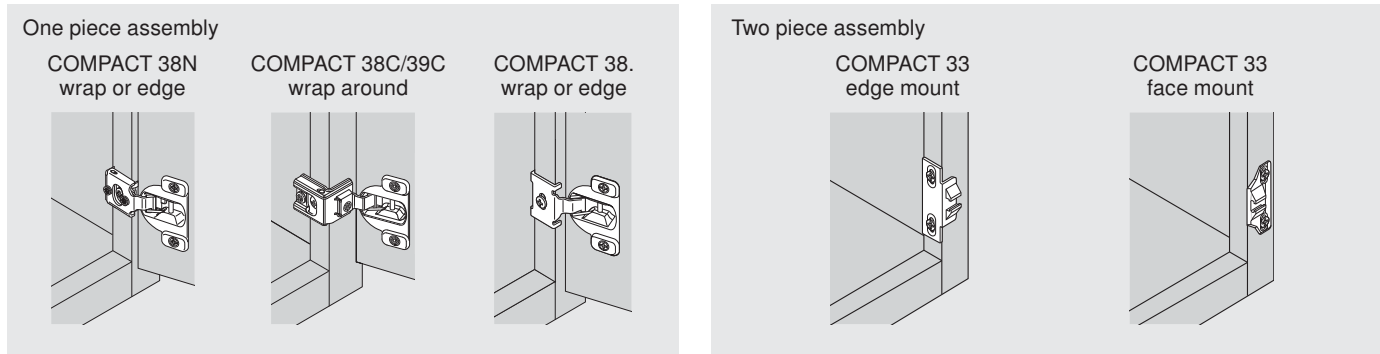

Hinge cup centerpoint

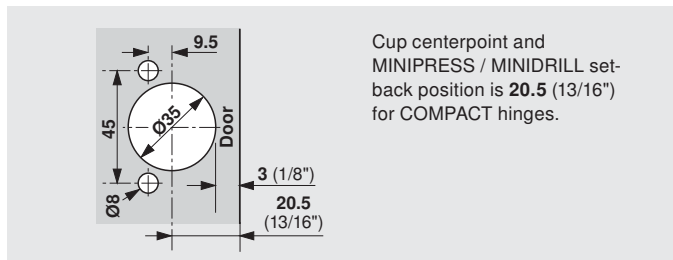

Minimum reveal

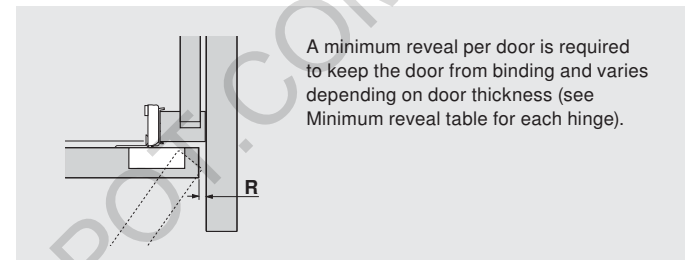

Three-way independent adjustment

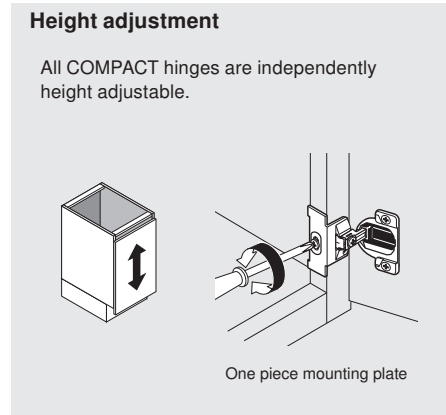
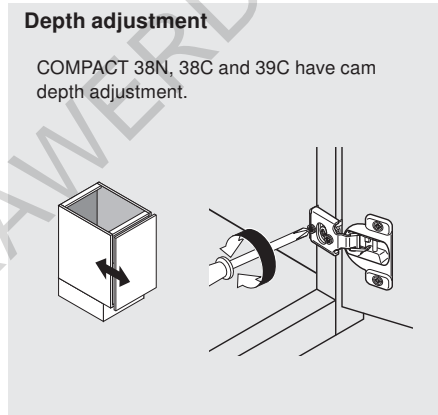
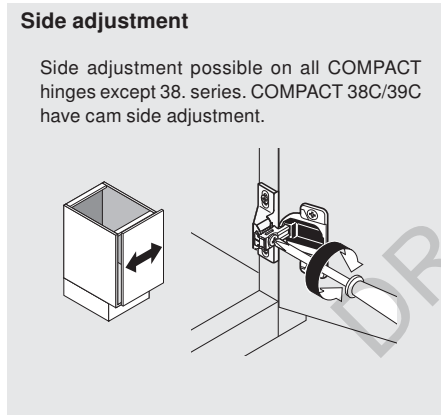

Hinge dimension abbreviations

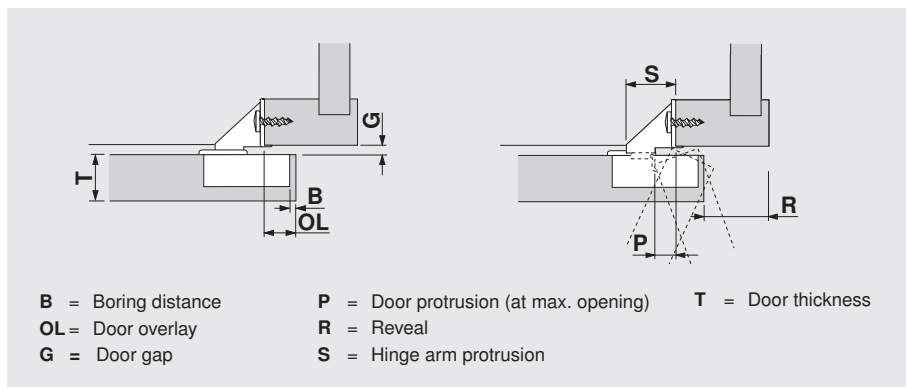

Hinges per door

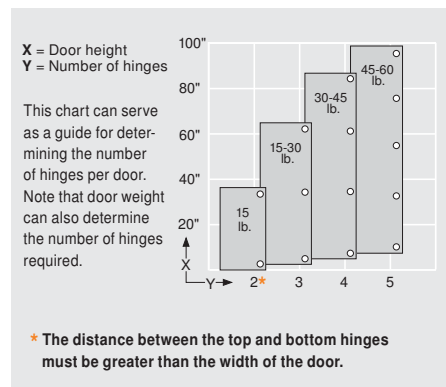



COMPACT 38N hinges



Features

- Steel, nickel plated
- 105° opening angle
- One piece assembly
- Wrap around or edge mount
- 7/16" cup depth
- ±1/8" height adjustment
- ±1/16" side adjustment
- +3/32" -1/32" cam depth adjustment

Minimum reveal

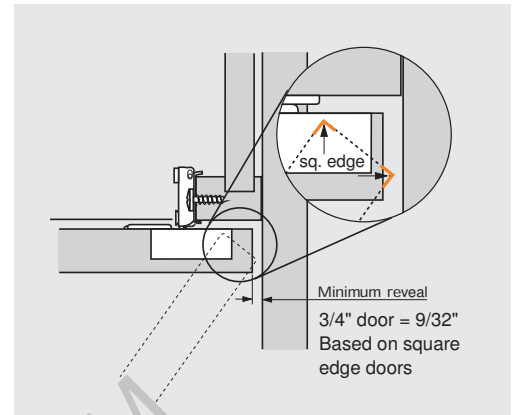

General specs & installation
Cover caps

page 65
page 72

Overlay application

Wrap around	3/8"	7/16"	1/2"	5/8"	3/4"
Screw-on	38N355C.06	38N355C.07	38N355C.08	38N355C.10	38N355C.12
Press-in	38N358C.06	38N358C.07	38N358C.08	38N358C.10	38N358C.12
Edge mount	1/2"				
Screw-on	38N355CE08				
Press-in	38N358CE08				

Attachment

Wrap around

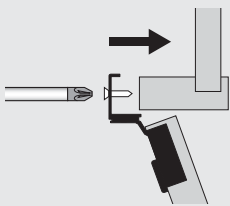

Edge mount

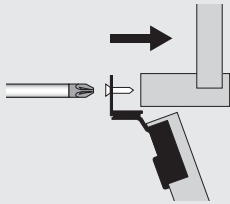

Wood screws



#10x3/4" pilot bore **1034N**



#8 x 3/4" type 17 **834TH**

Adjustment

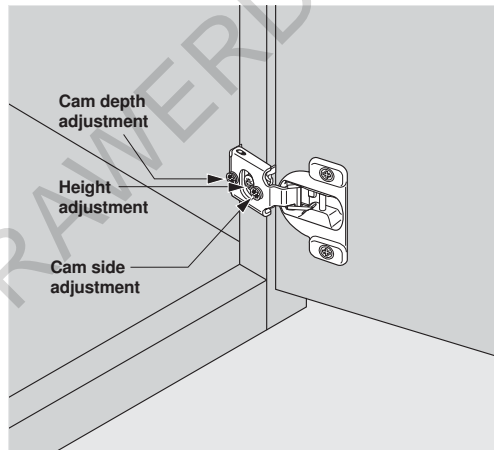

Dimensions

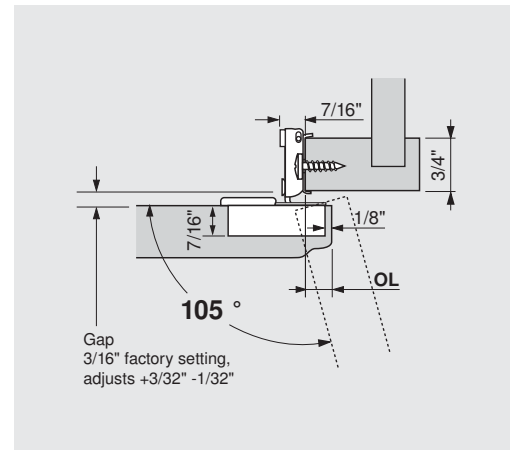

Boring pattern

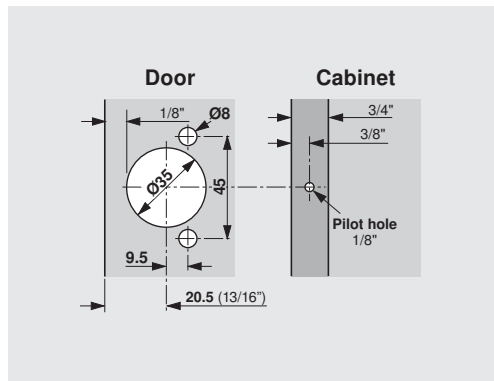

Door protrusion

OL	P
3/8"	1/4"
7/16"	3/16"
1/2"	1/8"
5/8"	0
3/4"	0

OL = Door overlay
P = Door Protrusion

COMPACT



COMPACT 38C hinges



Features

- Steel, nickel plated
- 107° opening angle
- One piece assembly
- Wrap around mount
- 7/16" cup depth
- ±1/8" height adjustment
- ±1/16" cam side adjustment
- +3/32" -1/32" cam depth adjustment

Minimum reveal

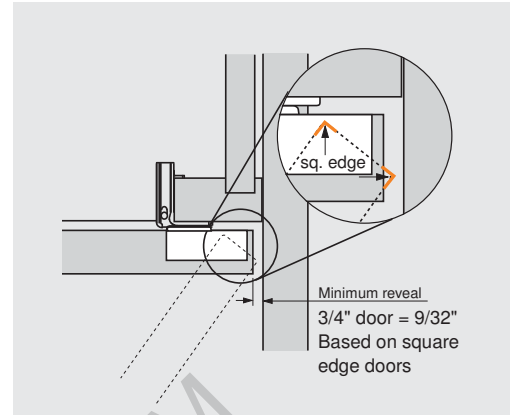

General specs & installation
Cover caps

page 65
page 72

Overlay application

Wrap around	1"	1-1/4"	1-5/16"	1-3/8"	1-1/2"	1-9/16"
Screw-on	38C355C.16	38C355C.20	38C355C.21	38C355C.22	38C355C.24	38C355C.25
Press-in	38C358C.16	38C358C.20	38C358C.21	38C358C.22	38C358C.24	38C358C.25

Attachment

Wrap around

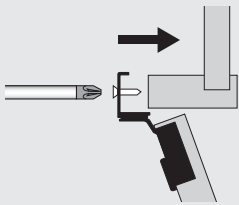

Adjustment

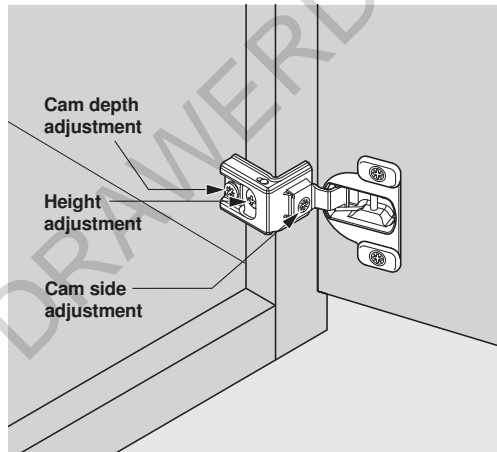

Dimensions

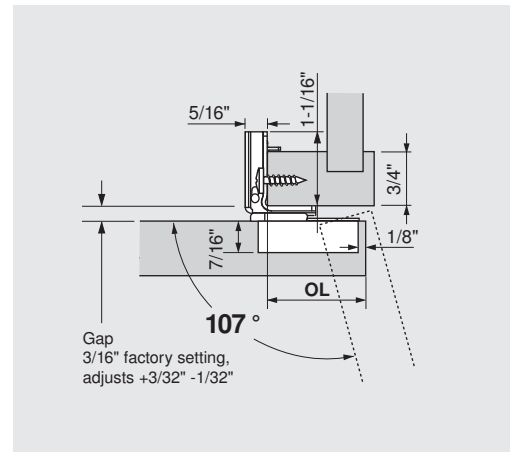

Boring pattern

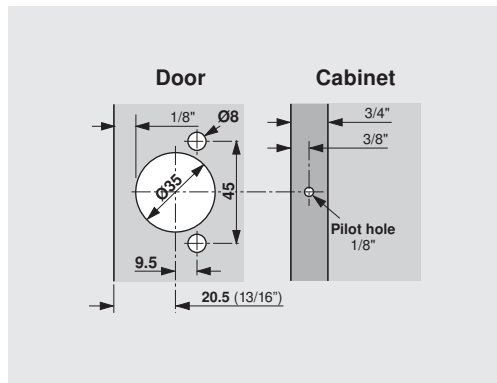

Wood screws



#10x3/4" pilot bore **1034N**



#8 x 3/4" type 17 **834TH**





COMPACT 39C hinges



Features

- Steel, nickel plated
- 110° opening angle
- One piece assembly
- Wrap around mount
- 1/2" cup depth
- ±1/8" height adjustment
- ±1/16" cam side adjustment
- +3/32" -1/32" cam depth adjustment

Minimum reveal

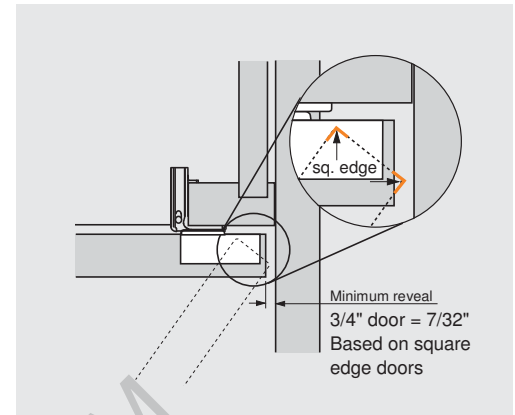

General specs & installation
Cover caps

page 65
page 72

Overlay application

Wrap around	1"	1-1/4"	1-5/16"	1-3/8"	1-1/2"	1-9/16"
Screw-on	39C355C.16	39C355C.20	39C355C.21	39C355C.22	39C355C.24	39C355C.25
Press-in 	39C358C.16	39C358C.20	39C358C.21	39C358C.22	39C358C.24	39C358C.25

Attachment

Wrap around

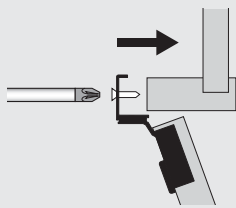

Adjustment

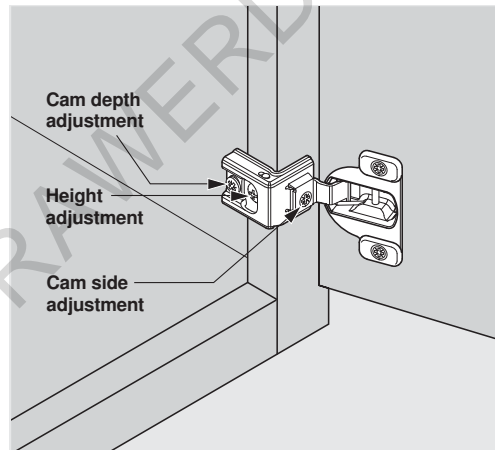

Dimensions

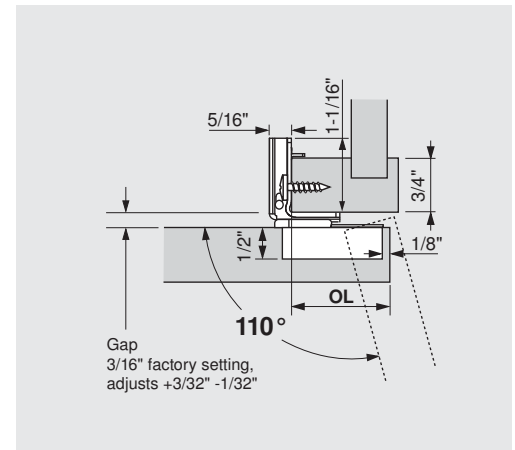

COMPACT

Wood screws



#10x3/4" pilot bore **1034N**



#8 x 3/4" type 17 **834TH**

Boring pattern

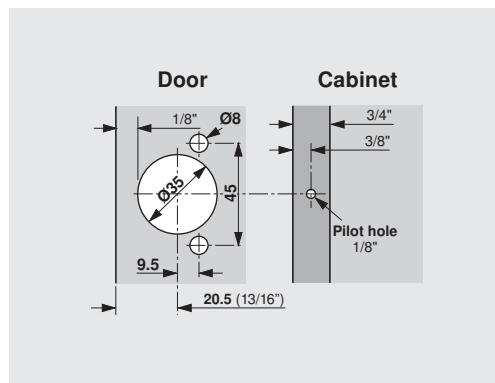



COMPACT 33 hinges



Features

- Zinc die-cast hinge and mounting plates
- 110° opening angle
- Two piece assembly
- Edge or face mount
- 1/2" cup depth
- $\pm 9/64$ " height adjustment
- $-1/8$ " side adjustment only

Minimum reveal

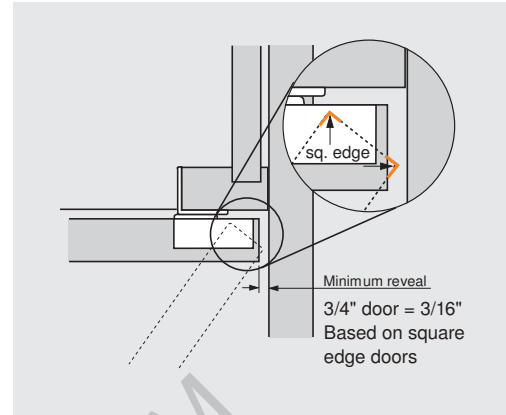

General specs & installation

page 65

Overlay Application

Screw-on	33.3600
Press-in	33.3630

Attachment

Edge mount

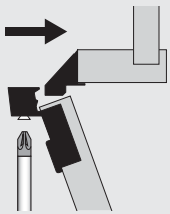

Face mount

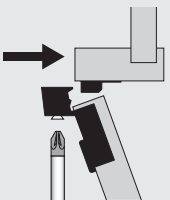

Mounting

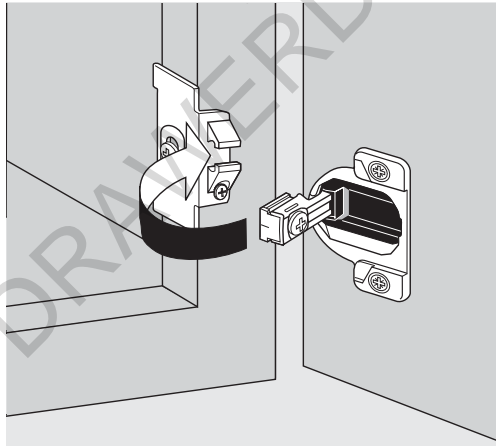

Dimensions

Vary by mounting plate (see page 70)

Boring pattern

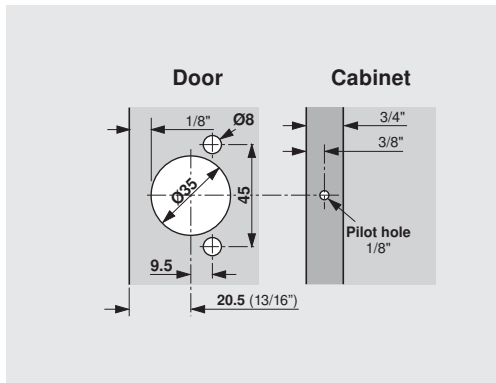

COMPACT

COMPACT 33 mounting plates

Edge mount mounting plates

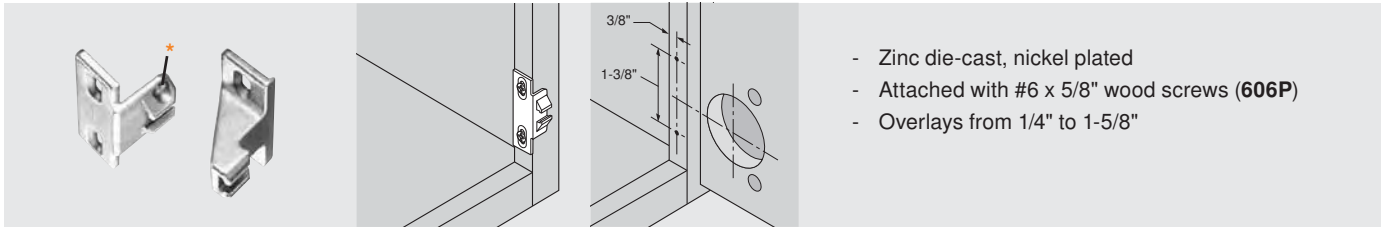

- Zinc die-cast, nickel plated
- Attached with #6 x 5/8" wood screws (**606P**)
- Overlays from 1/4" to 1-5/8"

Overlays	1/4"	1/2"	5/8"	3/4"	1"
* An additional attachment screw is required on mounting plates with 1-3/8" to 1-5/8" overlays to insure stability. Install after height adjustments have been made.	130.1100.24	130.1100.23	130.1100.26	130.1100.22	130.1110.02
	1-1/8"	1-1/4"	1-3/8"	1-1/2"	1-5/8"
	130.1120.02	130.1130.02	130.1140.02	130.1150.02	130.1160

Face mount mounting plates

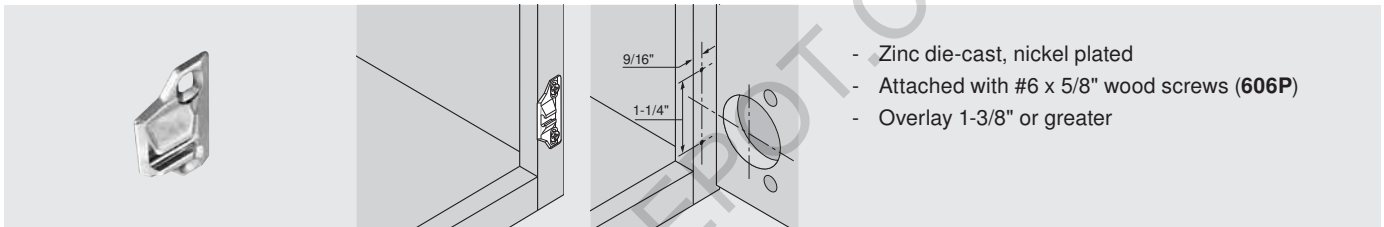

- Zinc die-cast, nickel plated
- Attached with #6 x 5/8" wood screws (**606P**)
- Overlay 1-3/8" or greater

Overlays	1-3/8" +
	133.0240

Mounting plate specifications

Minimum overlay of 1/4" using a 130.1100.24 edge mount plate

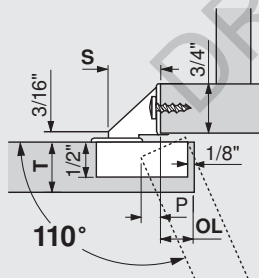

Maximum overlay of 1-5/8" using a 130.1160 edge mount plate

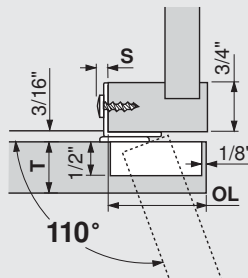

Hinge arm protrusion (**S**), and door protrusion (**P**), for **edge mount** mounting plates

Mounting Plate	OL	S	P
130.1100.24	1/4"	1-1/8"	1/2"
130.1100.23	1/2"	7/8"	1/4"
130.1100.26	5/8"	3/4"	1/8"
130.1100.22	3/4"	5/8"	0
130.1110.02	1"	3/8"	0
130.1120.02	1-1/8"	1/4"	0
130.1130.02	1-1/4"	3/16"	0
130.1140.02	1-3/8"	3/16"	0
130.1150.02	1-1/2"	3/16"	0
130.1160	1-5/8"	3/16"	0

COMPACT



COMPACT 38. hinges



Features

- Steel, nickel plated
- 105° opening angle
- One piece assembly
- Self-closing
- Wrap around or edge mount
- 7/16" cup depth
- ±1/8" height adjustment

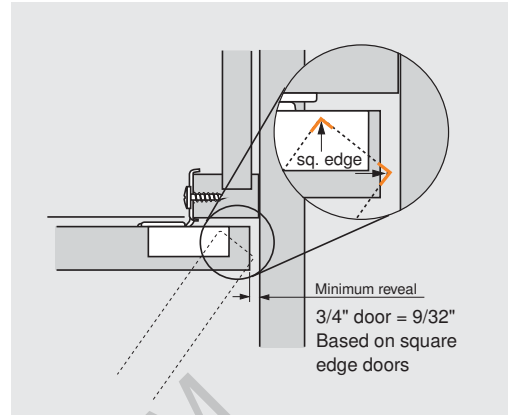

Minimum reveal



General specs & installation

page 63

Overlay Application

Wrap around	7/16"	1/2"
Press-in 	38.3580.07	38.3580.08
Edge mount		1/2"
Press-in 		38.3580E08

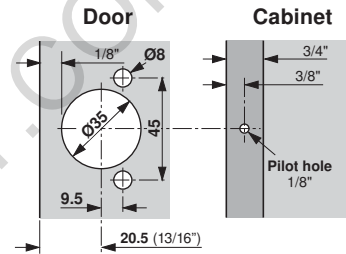

Attachment

Wrap around or edge mount

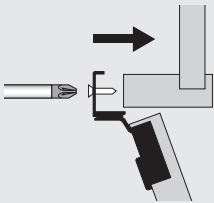

Adjustment

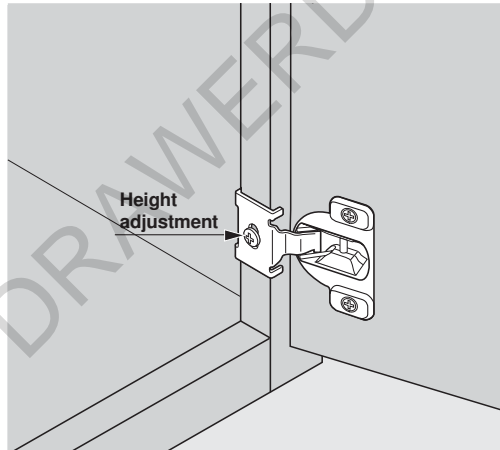

Dimensions

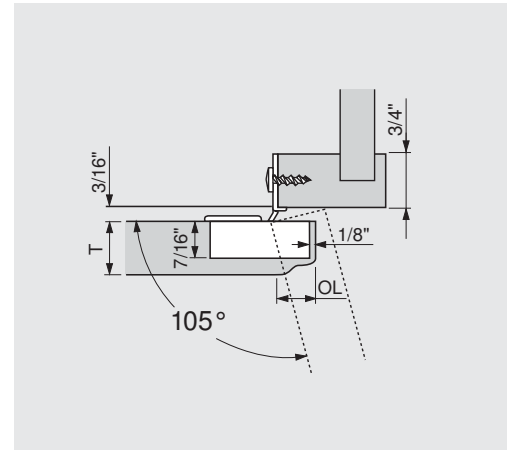

Distance spacer for 38. hinges

Decreases door overlay in 1/32" increments. Can be stacked to achieve desired overlay reduction. Zinc coated steel.

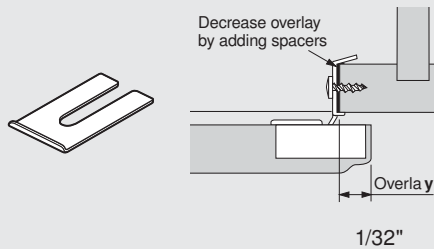

Door protrusion

OL	S	P
7/16"	5/16"	3/16"
1/2"	1/4"	1/8"

OL = Door overlay
S = Hinge protrusion
P = Door protrusion

Wood screws



#10x3/4" pilot bore **1034N**



#8 x 3/4" type 17 **834TH**

38. Distance spacer **36.3515**



COMPACT cover caps

COMPACT 38N cover caps



Features

- Steel, nickel plated
- Available for COMPACT 38N and COMPACT 38/39C series hinges
- Clip on attachment/removal
- Available blank or with printed custom logo (minimums apply)

COMPACT 38/39C cover caps



Attachment

38N

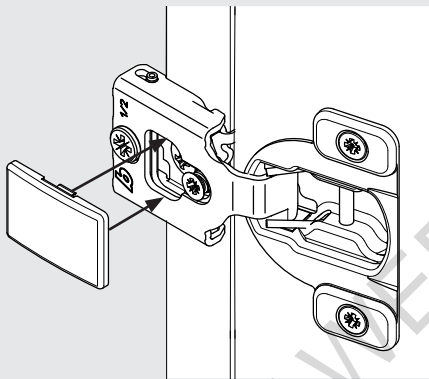

Stainless steel cover caps
For COMPACT 38N hinges

Part no.
38N3508

38/39C

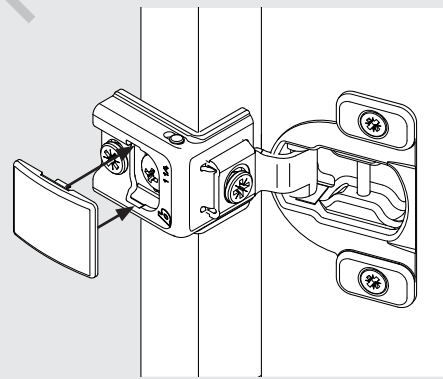

Stainless steel cover caps
For COMPACT 38/39C hinges

Part no.
38C3508

38N cutouts

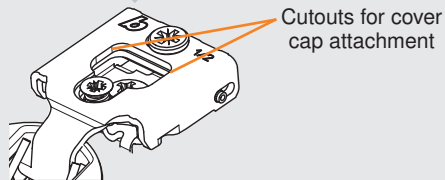

38/39C cutouts

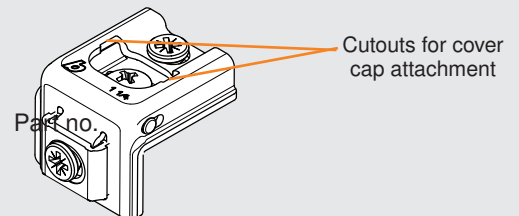

NOTE: Custom logo available. Consult your Blum representative for minimum quantities and lead times on custom logos.

COMPACT

DRAWERDEPOT.COM



Machines & assembly aids

Templates and accessories

ECODRILL and accessories

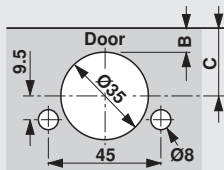
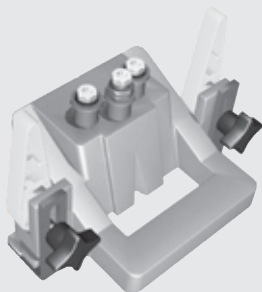

Blum boring pattern

- Simple device for boring Blum hinge pattern
- Driven by electric/cordless drill (14v or better)
- Each drill bit is driven separately and retracts automatically
- Variable boring distance from 2 mm to 8 mm
- Clamps to various door thicknesses up to 40 (1-9/16")
- Includes drill bits (pre-installed) and two Torx driver bits

Part no.

ECODRILL	M31.1000
Replacement Ø35 mm bit	M31.ZB35.02
Replacement Ø8 mm bit	M31.ZB08.02
Tool set	MZW.1300

ECODRILL and Torx bits (included)

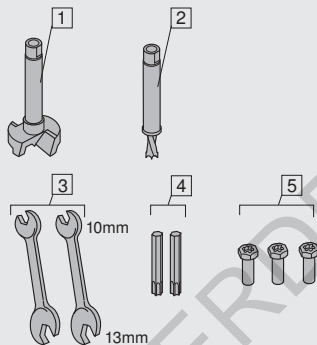
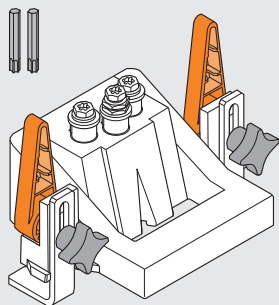

Replacement drill bits

- | | |
|---|------------------|
| 1 | Ø35 mm drill bit |
| 2 | Ø8 mm drill bit |

Tool Set

- | | |
|---|--------------------|
| 3 | 2 wrenches |
| 4 | 2 Torx driver bits |
| 5 | 3 Torx chucks |

Using the ECODRILL

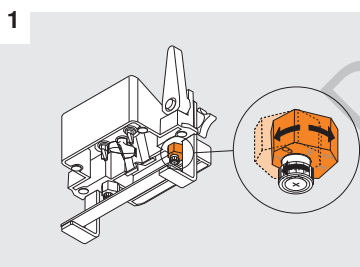

1 Set boring distance cams by rotating to the desired position

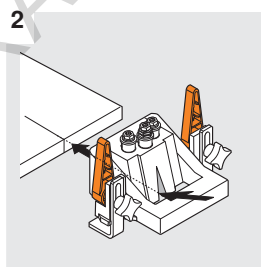

2 Align ECODRILL body with hinge center line marked on the door

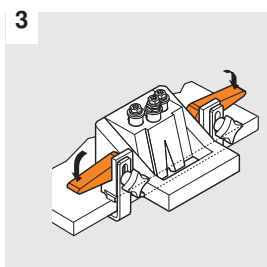

3 Secure ECODRILL to the door by rotating the clamp arms

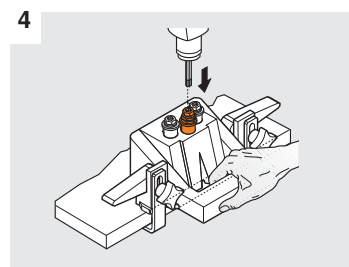

4 With the Torx bit, bore the three holes separately

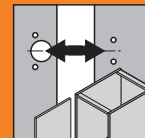

ECOJIG boring template for mounting plates

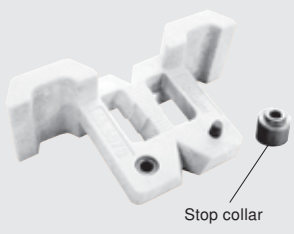

Stop collar

Holes are:
32mm apart,
37mm setback

- Use to bore Ø5 mm holes for mounting plates that are mounted with system screws, EXPANDO dowels or INSERTA
- Ø5 mm stop collar included

Part no.	65.5070
ECOJIG	DB-5mm
Ø5 mm bit	

Using the ECOJIG

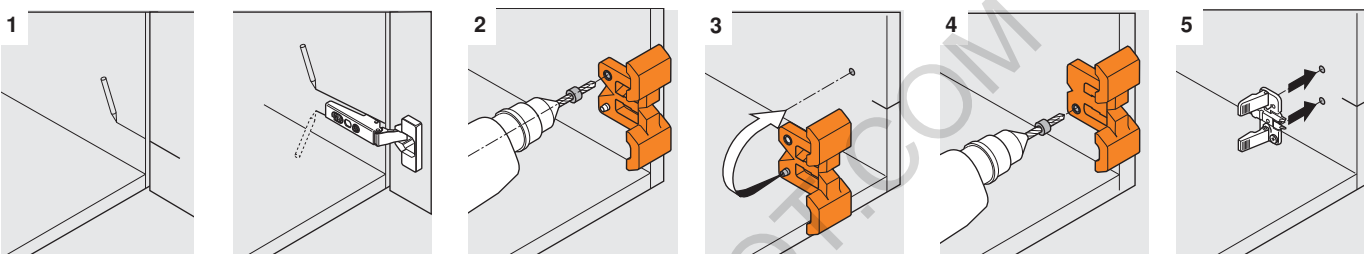

1. Mark hinge center line, or hinge arm outline, on cabinet side panel
2. Align template with marks and drill top Ø5 mm hole
3. Flip template over and seat locator pin into top hole
4. Drill the bottom Ø5 mm hole
5. Install INSERTA, EXPANDO or system screw mounting plate

Universal individual template

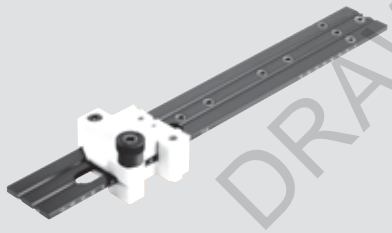

- For marking and pre-boring of wing or in-line mounting plates
- Can be used for marking and pre-boring BLUMOTION and TIP-ON adapter plates
- Can be used for pre-boring AVENTOS locating pins
- Can be used for marking and pre-boring cabinet profiles
- Calibrated scale for accurate setting

Set includes:

- Universal individual template
- Ø2.5 mm and Ø5 mm stop collars

Part no.	65.1051
Template	DB-2.5mm
Ø2.5 mm bit	
Ø5 mm bit	DB-5mm

Using the Universal individual template

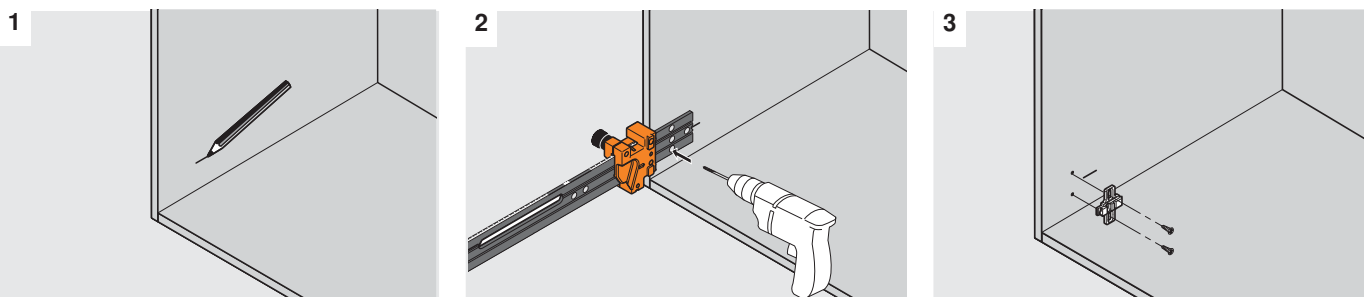

1. Mark the position of the mounting plate
2. Line up template with mark and pre-bore required holes
3. Attach mounting plate

Templates and accessories

QUICKFIX

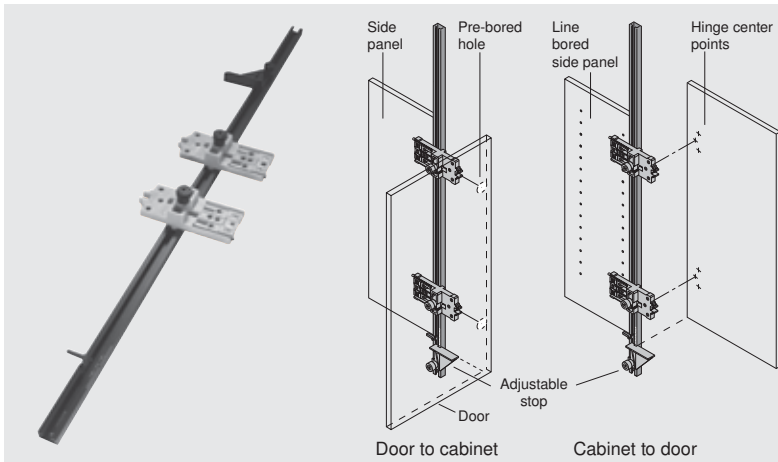

- Simple device to locate hinge and plate positions
- Transfer positions from door-to-cabinet and from cabinet-to-door
- Positions can be transferred from either assembled or unassembled cabinets
- Adjustable stop for various door overlays has calibration to simplify set-up
- For use with wing or in-line mounting plates

Part no.

QUICKFIX

65.7500.01

Specifications

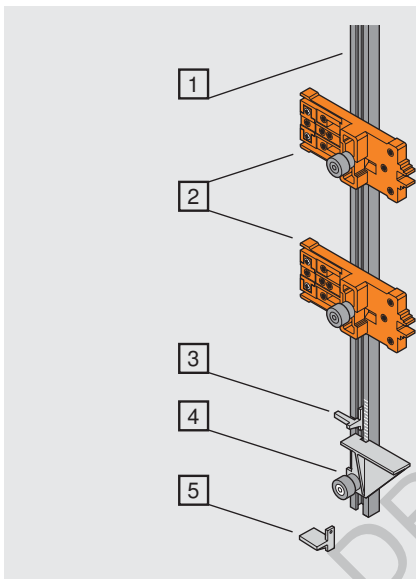

QUICKFIX parts included

- | | |
|---|--|
| 1 | Rail, 1 meter long |
| 2 | Template with marking pin (2 included) |
| 3 | Fixed inner stop |
| 4 | Adjustable overlay stop |
| 5 | Fixed outer stop |

Accessories for QUICKFIX

Additional CLIP template	65.7510.01
MODUL template	65.9510
2.2 meter rail	65.7590
Ø5 mm drill bit	DB-5mm

Part no.

22 mm setback mounting plate template

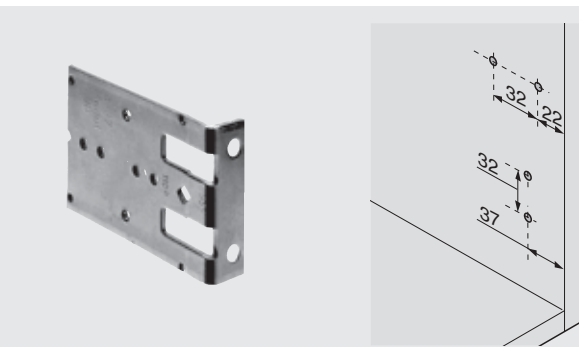

- For pre-boring wing mounting plates and 22 mm setback in-line mounting plates
- Simple location of mounting plate screw positions
- Transfers measurements from door to cabinet
- If mounting plates are standard, multiple templates can be attached to a wooden strip
- Pilot bores Ø2.5 mm holes for wood screws

Part no.

Mounting plate template

65.5310

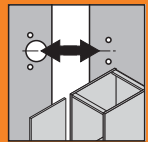

PlateMate

Adjustable

M4 x 25mm spacer screws included

- Boring template for all Blum face frame adapter plates
- Clamps to the frame with cam lever
- Adjustment knob accommodates frame thickness of 5/8" to 1"
- Spacer screws permit quick use without measuring
- Includes:
 - Ø2.5 mm pilot bit and drill bit extension
 - reversible bushing insert for 32 mm hole spacing (for 175L6xxx)
 - reversible bushing insert for 40 mm hole spacing (for 175H6xxx)
 - bushings reverse from 9.5 mm to 12.5 mm setback

PlateMate	65.5030.01
Ø2.5 mm drill bit	DB-2.5mm

Using the PlateMate

Boring pilot holes for **inset** face frame adapter plate

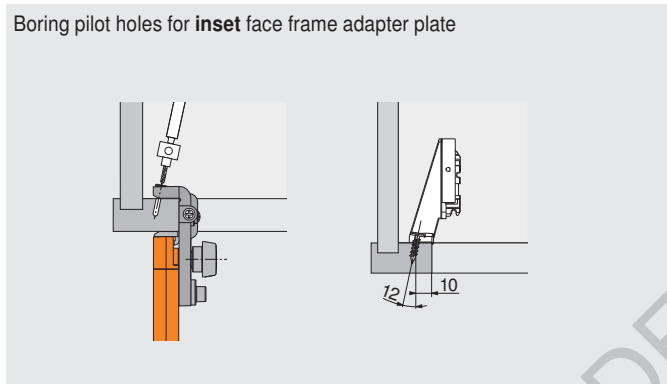

Boring pilot holes for **overlay** face frame adapter plate

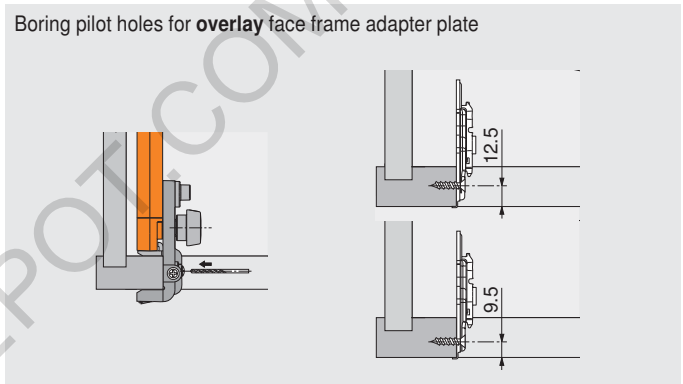

INSERTA boring template

Guides for boring Ø8 holes

Centerline locators

Guides for Ø5 holes

Ø35 flange fits in pre-bored hole

Two rotating cams provide seven boring settings for hinge cups

- For installing Blum hinges with INSERTA or EXPANDO cups
- For boring Ø8 mm dowels after Ø35 mm hole is bored
- Boring distance adjusts from 2 to 8 mm
- Template for boring Ø5 mm holes for system screw mounting plates
- Includes drill bushing to pilot bore Ø2.5 mm for wood screw plates

INSERTA boring template	65.0590
Ø8 mm drill bit	DB-8mm
Ø5 mm drill bit	DB-5mm

Using the INSERTA boring template for hinges

1

Prebore door with Ø35 mm bit

2

Set boring distance, position in hole and bore Ø8 mm dowel holes

Using the INSERTA boring template for mounting plates

1

Position template on centerline

2

Drill holes for mounting plates with Ø5 or Ø2.5 mm bit

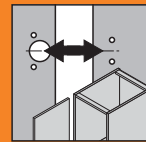

Screws, bumpers and POZI driver

Screws

Wood screws	Head diameter	Length	Head	Part no.
	#6	13 (1/2")	#2 Phillips	6062N
	#6	16 (5/8")	#2 Phillips	606N
	#6	16 (5/8")	#2 POZI	606P
	#6	19 (3/4")	#2 Phillips	6064N
	#7	16 (5/8")	#2 Phillips	707N
	#7	19 (3/4")	#2 Phillips	7074N

Truss and Panhead screws	Head diameter	Length	Head	Part no.
	#8	19 (3/4"), type 17	#2 Phillips	834TH
	#10	19 (3/4")	#2 Phillips	1034N

System screws	Hole diameter	Length	Head	Part no.
	5	10 (13/32")	#2 POZI	661.1000.HG
	5	11.5 (15/32")	#2 POZI	661.1150.HG
	5	13 (1/2")	#2 POZI	661.1300.HG
	5	14.5 (9/16")	#2 POZI	661.1450.HG
	5	20 (25/32")	#2 POZI	661.2000.HG
	5	25 (1")	#2 POZI	661.2500.HG
	5	30 (1-3/16")	#2 POZI	661.3000.HG
	5	14.5 (9/16")	#2 POZI pan head	668.1450.EH

*Replacement screw for plates with Pre-mounted system screws

Twin application screws	Hole diameter	Length	Type	Head	Range	Part no.
	5	14 (9/16")	Male	Slot	-	612.2010
	5	20 (25/32")	Female	Slot	16-20	612.2020
	5	24 (15/16")	Female	Slot	20-24	612.2420

Bumpers

Adhesive backed	Diameter	Thickness	Color	Part no.
	7.5 mm	2 mm	Clear	FX4041
	12 mm	3.5 mm	Clear	SJ5312

POZI screwdriver and bits

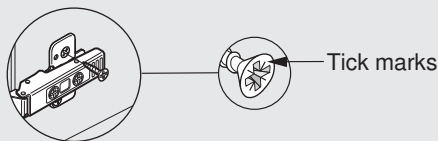
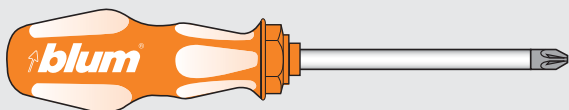

A POZI screwdriver (different from Phillips) is the most crucial tool you can use to assure that full torque is applied to all Blum adjustment screws. POZI screws can be identified by the distinctive "tick" marks located in the center of the screw head recess.

	Part no.
#2 POZI driver	POZI DRIVER
1/4" Magnetic bit holder	BIT HOLDER
#2 x 1" POZI bit insert	POZI BIT #2x1
#2 x 2" POZI bit insert	POZI BIT #2x2

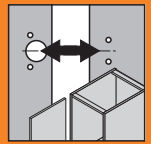

Dowel cross-reference

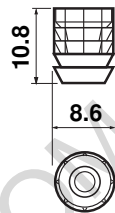
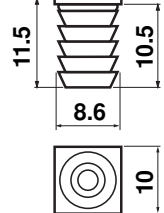

Blum press-in and EXPANDO dowels simplify installation. Use the chart below to find the proper hinge - dowel combination.

All dowels for Ø8 mm hole and require a #6 x 1/2" dowel screw (608.1200)				
Dowels for Ø8 mm hole			70.0532	34.3582.01
Type	Series	Cup material	without flange	with flange
COMPACT	33	Zinc	✓	
	38C / 39C	Steel	✓	✓
	38N		✓	✓
	38.		✓	✓
CLIP top and CLIP	100° / 107°	Steel	✓	
	120° / 120°+		✓	
	170°		✓	
	Thick door		✓	
	Zero protrusion		✓	
	Diagonal 45°		✓	
	Blind corner	✓		
MODUL	Bi-fold	Zinc	✓	
	100°	Steel	✓	
	170°		✓	
	Blind corner		✓	

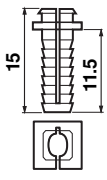
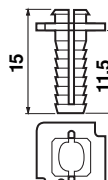
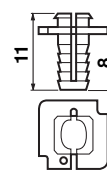
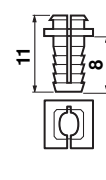
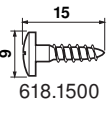
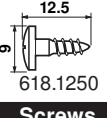
All dowels for Ø5 mm hole (Blum mounting plates)								
Type	Series	Application	Dowels				Screws	
EXPANDO	174H7100E	std. application	174H7100E8				618.1500	
	174E6100.01			174E6102			618.1500	
	174H710ZE	twin application			174H710E8Z		618.1250	
	174E610Z					174E610Z4	618.1250	

All dimensions in millimeters (inch equivalents as shown). Subject to technical modifications without notice. © 2008

Machines

MINIPRESS P - Deluxe boring and insertion machine

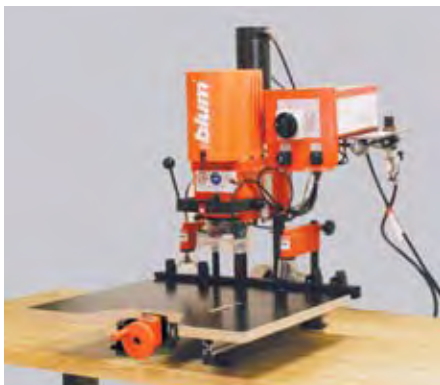

As a boring and hardware insertion specialist, MINIPRESS P Deluxe takes on the routine jobs in the workshop producing precise assembly results. The MINIPRESS P Deluxe is an efficient machine designed to bore all hinge and mounting plate systems, and three-hole line boring of cabinet sides.

Features:

- Front adjustable boring distance with digital calibration
- Pneumatic hold-down clamps
- Improved boring depth adjustment
- Improved positioning stops (4)
- Tool set included
- Dust collection attachment
- Accepts optional 7 or 8 spindle boring heads

Optional items:

- Laser center line set (220V power only) **Part no. MZR.5300.US**

Single phase - 220V power <i>Laser center line optional.</i>	Part no. M53.1053.US
Three phase - 220V power <i>Laser center line optional.</i>	Part no. M53.1004.US
Three phase - 440V power <i>No laser center line option.</i>	Part no. M53.1005.US

MINIPRESS P - Standard boring and insertion machine



MINIPRESS P Standard is a more cost effective boring and insertion machine. The MINIPRESS P Standard is an efficient machine designed to bore all hinge and mounting plate systems, and three-hole line boring of cabinet sides.

Features:

- Front adjustable boring distance
- Improved boring depth adjustment
- Improved positioning stops (4)
- Tool set included
- Dust collection attachment
- Accepts optional 7 or 8 spindle boring heads

Optional items:

- Laser center line set **Part no. MZR.5300.US**
- Digital calibration set **MZE.2110**
- Hold down clamp set **M53.0720.US**

Single phase - 220V power <i>Laser center line, hold down clamps and digital calibration optional.</i>	Part no. M53.1053.US
---	-----------------------------

Assembly aids



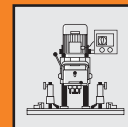

MINIPRESS M - 110V manual boring and insertion machine



The new MINIPRESS M is a robust tool that is flexible enough to be used on-site or in the workshop. MINIPRESS M operates on 110 voltage and does not require pressurized air. The MINIPRESS M is a simple and efficient machine designed to bore and insert all hinge and mounting plate systems, and three-hole line boring of cabinet sides.

Features:

- 110V power with molded plug (portable)
- Does not require pressurized air
- 4 positioning stops included
- Tool set included
- Dust collection attachment
- Accepts optional 7 or 8 spindle boring heads

Optional items:

- Boring distance stop set Part no.
MZS.1020

110V power

Boring distance stop set optional.
No laser center line option.

Part no.
M52.1056.US

MINIDRILL P - Standard boring machine



The MINIDRILL P is a simple and efficient machine designed to bore all hinge and mounting plate systems, and three-hole line boring of cabinet sides.

Features:

- Front adjustable boring distance
- Improved boring depth adjustment
- Improved positioning stops (4)
- Tool set included
- Dust collection attachment
- Accepts optional 7 or 8 spindle boring heads

Optional items:

- Laser center line set Part no.
MZR.5300.US
- Digital calibration set **MZE.2110**
- Hold down clamp set **M53.0720.US**

Single phase- 220V power

Optional hold down clamps, laser center line and digital calibration.

Three phase - 220V power

Optional hold down clamps, laser center line and digital calibration.

Three phase - 440V power

Optional hold down clamps and digital calibration. No laser center line option.

Part no.
M53.1053.50

M53.1004.50

M53.1005.50

Assembly aids

Machine accessories

7 spindle heads



7 spindle head features:

- Bores 7 holes, spaced 32 mm apart, parallel to the fence
- Retractable index pins located on both sides permit continuous boring
- Bores for 32 mm system

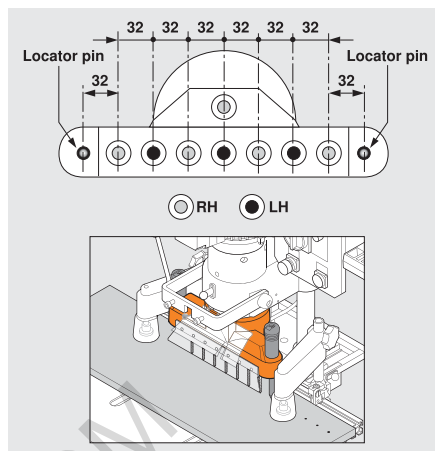

7 spindle head

Part no.

MZK.1000.US

8 spindle heads



8 spindle head features:

- Bores 8 holes, spaced 32 mm apart, perpendicular to the fence
- Bores for all METABOX and TANDEMBOX front fixing brackets and galleries
- Bores cabinet side panels for all Blum runner systems (except SOLO)

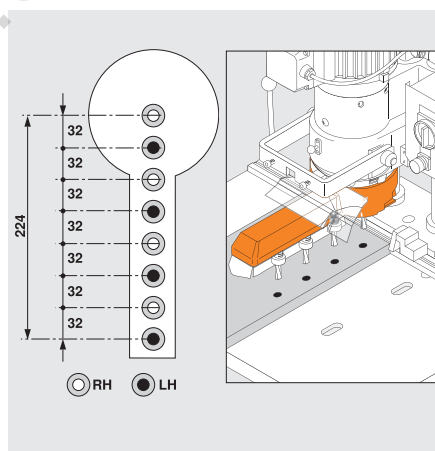

8 spindle head

Part no.

MZK.8000.US

Insertion rams



Part no.

For 107/120 hinges	MZM.0010
For 100/thick door hinges	MZM.0011
For 170 hinges	MZM.0018
For blind corner hinges	MZM.0019
For diagonal 45 hinges	MZM.0019
For bi-fold hinges	MZM.0021
For COMPACT hinges	MZM.0037
For insertion of dowels into door	MZM.0038
Replacement pins for the MZM.0038	MZM.0383
For In-line mtg. plates	MZM.0050



Machine accessories

1 Work table

2 Work table

3 Center ruler

4 Extension ruler

5 Ruler stops, left or right

6 Small ruler stop, left or right

7 Large ruler stop, symmetrical

8 Center position indicator

9 Fixed depth stop

10 Digital counter set

11 Hold down clamp set

12 Laser center point set

13 Boring distance stop set

14 Break away clutch

Accessories (order separately)

	Part no.
1 Work table for MINIPRESS P /MINIDRILL P	MZA.5300
2 Work table for MINIPRESS M	MZA.1000
3 Center ruler, 600 mm (2')	M30.0212
4 Extension ruler, length 1250 mm (4')	MZL.1250.US
5 Ruler stop, left or right	MZS.3000
6 Small ruler stop, left or right	MZS.2000
7 Large ruler stop, symmetrical	MZS.1000
8 Center position indicator	MZR.2000
9 Fixed depth stop for 13 mm (1/2")	M30.1304
10 Digital counter set	MZE.2110
11 Hold down clamp set	M53.0720.US
12 Laser center point set	MZR.5300.US
13 Boring distance stop set (MINIPRESS M only)	MZS.1020
14 Replacement break away clutch for MINIPRESS and MINIDRILL	MZK.2009

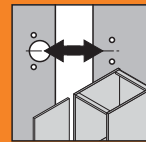

Knock-in tool and drill bits

Mounting plate knock-in tool

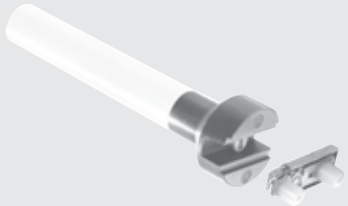

Knock-in tool

Magnet

177H5100 plate

- Magnet holds mounting plate making insertion easier
- Made of hardened steel with durable acrylic handle
- For use with mounting plate: 177H51x0 and 175H54x0x

Part no.

Knock-in hand tool **65.6100**

Drill bits

																													
Ø5 mm	Ø8 mm	Ø10 mm	Ø35 mm	<table border="0" style="width: 100%;"> <tr><td>Ø5 mm drill bit (RH)</td><td>M01.ZB05.D2 R</td></tr> <tr><td>Ø5 mm drill bit (LH)</td><td>M01.ZB05.D3 L</td></tr> <tr><td>Ø8 mm drill bit (LH)</td><td>M01.ZB08.03 L</td></tr> <tr><td>Ø10 mm drill bit (RH)</td><td>M01.ZB10.02 R</td></tr> <tr><td>Ø10 mm drill bit (LH)</td><td>M01.ZB10.03 L</td></tr> <tr><td>Ø20 mm drill bit (RH)</td><td>M01.ZB20.02 R</td></tr> <tr><td>Ø35 mm drill bit (RH)</td><td>M01.ZB35.02 R</td></tr> </table>	Ø5 mm drill bit (RH)	M01.ZB05.D2 R	Ø5 mm drill bit (LH)	M01.ZB05.D3 L	Ø8 mm drill bit (LH)	M01.ZB08.03 L	Ø10 mm drill bit (RH)	M01.ZB10.02 R	Ø10 mm drill bit (LH)	M01.ZB10.03 L	Ø20 mm drill bit (RH)	M01.ZB20.02 R	Ø35 mm drill bit (RH)	M01.ZB35.02 R											
Ø5 mm drill bit (RH)	M01.ZB05.D2 R																												
Ø5 mm drill bit (LH)	M01.ZB05.D3 L																												
Ø8 mm drill bit (LH)	M01.ZB08.03 L																												
Ø10 mm drill bit (RH)	M01.ZB10.02 R																												
Ø10 mm drill bit (LH)	M01.ZB10.03 L																												
Ø20 mm drill bit (RH)	M01.ZB20.02 R																												
Ø35 mm drill bit (RH)	M01.ZB35.02 R																												
				Countersink drill bits	Part no.																								
				Ø8 mm drill bit (LH)	T108-8mm L																								
				Ø10 mm drill bit (RH)	T108-10mm R																								
				Ø10 mm drill bit (LH)	T108-10mm L																								
																													
T108	VPB-5	<p>Chuck for DB-2mm</p> <p>Use to pilot bore for screw-on hinges with MINIPRESS or MINIDRILL</p>	Twist drill bit	<table border="0" style="width: 100%;"> <tr><td colspan="2">Twist drill bits - high speed steel</td><td>Part no.</td></tr> <tr><td colspan="2">VPB-5 centering bit</td><td>VPB-5</td></tr> <tr><td colspan="2">Ø2 mm left</td><td>DB-2mm</td></tr> <tr><td colspan="2">Ø2.5 mm right</td><td>DB-2.5mm</td></tr> <tr><td colspan="2">Ø5 mm right</td><td>DB-5mm</td></tr> <tr><td colspan="2">Ø8 mm right</td><td>DB-8mm</td></tr> <tr><td colspan="2">Ø10 mm right</td><td>DB-10mm</td></tr> <tr><td colspan="2">Ø10 mm chuck for DB-2mm</td><td>DB-10 x 2mm</td></tr> </table>	Twist drill bits - high speed steel		Part no.	VPB-5 centering bit		VPB-5	Ø2 mm left		DB-2mm	Ø2.5 mm right		DB-2.5mm	Ø5 mm right		DB-5mm	Ø8 mm right		DB-8mm	Ø10 mm right		DB-10mm	Ø10 mm chuck for DB-2mm		DB-10 x 2mm	
Twist drill bits - high speed steel		Part no.																											
VPB-5 centering bit		VPB-5																											
Ø2 mm left		DB-2mm																											
Ø2.5 mm right		DB-2.5mm																											
Ø5 mm right		DB-5mm																											
Ø8 mm right		DB-8mm																											
Ø10 mm right		DB-10mm																											
Ø10 mm chuck for DB-2mm		DB-10 x 2mm																											



Testing Standards

Hinge and mounting plate testing



All Blum products undergo strict quality control procedures through all stages of production. All concealed hinges are designed for indoor use only. Careful attention must be paid to installation or operating instructions when using Blum products (see catalogs or operating manuals for all technical information).

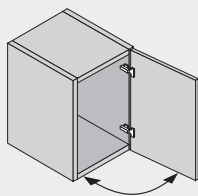

Cycle test
200,000 opening and closing cycles for Euro hinges.
100,000 opening and closing cycles for CLIP mini and all COMPACT hinges.

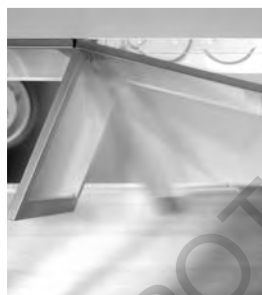

Cycle test with load
11 lbs. extra weight applied for 100,000 opening and closing cycles.

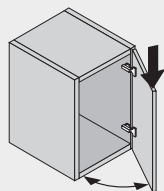
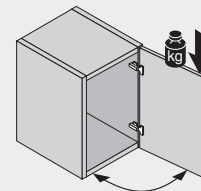

Static load test
67 lbs. applied 10 times for 5 seconds each at 45 degree opening angle.



Dynamic load test
44 lbs. extra weight applied for 50 opening and closing cycles.

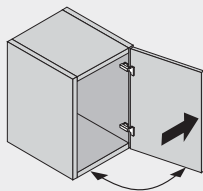
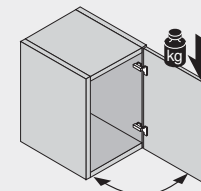

Over push test
11 lbs. applied 10 times for 5 seconds each.



All Blum hinges and mounting plates must pass these tests without showing a measurable reduction in performance or deviation in adjustment position. Testing standards vary between products and applications.

All Blum hinges meet or exceed ANSI/BHMA A156.9-2001 grade 2 requirements.

Part number index

Part no.	Page No.						
1034N	66-68,71,79	175L6630.22	51	39C355C.25	68	70T6650	14
130.1100.22	70	175L6660.22	51	39C358C.16	68	70T6680	14
130.1100.23	70	175L8100	49	39C358C.20	68	70T9550.TL	18
130.1100.24	70	175L8130	49	39C358C.21	68	70T9580.TL	18
130.1100.26	70	175L8190	49	39C358C.22	68	70T9650.TL	18
130.1110.02	70	177H5100	50	39C358C.24	68	70T9750.TL	18
130.1120.02	70	177H5130	50	39C358C.25	68	71.6540B	30
130.1130.02	70	181.6130	15,37	6062N	79	71.6550	30
130.1140.02	70	193L6100	57	6064N	79	71.6580	30
130.1150.02	70	193L8100	57	606N	79	71.6650	30
130.1160	70	195H7100	57	606P	79	71.6680	30
133.0240	70	195H7190	57	612.2010	79	71M2550	28
171A5010	34,37-39,41-44	195H9100	58	612.2020	79	71M2580	28
171A5040	34,37,42,43	198.6600.23	58	612.2420	79	71M2590B	28
171A5070	34,37,38,40,44	198.6660.22	58	618.1250	80	71M2650	28
171A5500	34,37-39,41-44	199.0100.02	58	618.1500	80	71M2680	28
173H7100	37-44,48	33.3600	69	65.0590	78	71M2690B	28
173H7130	37,40-43,48	33.3630	69	65.1051	76	71M2750	28
173H7160	44	34.3582.01	80	65.5030.01	78	71M2780	28
173H9100	48	36.3515	71	65.5070	76	71M2790B	28
173H9130	48	38.3580.07	71	65.5310	77	71T0550	25
173L6100	47	38.3580.08	71	65.6100	85	71T0650	25
173L6130	47	38.3580E08	71	65.7500.01	77	71T0750	25
173L8100	47	38C3508	72	65.7510.01	77	71T5550	12
173L8130	47	38C355C.16	67	65.7590	77	71T5580	12
174E6100.01	47,80	38C355C.20	67	65.9510	77	71T558E	12
174E6102	80	38C355C.21	67	661.1000.HG	79	71T5590B	12
174E610Z	47,80	38C355C.22	67	661.1150.HG	79	71T560A	21
174E610Z4	80	38C355C.24	67	661.1300.HG	79	71T560AB	20
174E6130.01	47,80	38C355C.25	67	661.1450.HG	79	71T5650	12
174H7100E	48,80	38C358C.16	67	661.2000.HG	79	71T5680	12
174H7100E8	80	38C358C.20	67	661.2500.HG	79	71T5690B	12
174H7100I	49	38C358C.21	67	661.3000.HG	79	71T6540B	14
174H710E8Z	80	38C358C.22	67	668.1450.EH	79	71T6550	14
174H710ZE	48,80	38C358C.24	67	69.3600	77	71T6580	14
174H7130E	48	38C358C.25	67	70.0532	80	71T6640B	14
175H5030.21	51	38N3508	72	70.1503	31	71T6650	14
175H5100.05	50	38N355C.06	66	70.1563	31	71T6680	14
175H6000	27, 50	38N355C.07	66	70.1663	31	71T7500B	19
175H6030	50	38N355C.08	66	70.6103	15,31	71T7530B	19
175H6040	50	38N355C.10	66	7074N	79	71T7540B	19
175H6060	50	38N355C.12	66	707N	79	71T9550	18
175H6600	50	38N358C.06	66	70M2550.TL	28	71T9580	18
175H7100	49	38N358C.07	66	70M2580.TL	28	71T9590B	18,34,37-39,43
175H7130	49	38N358C.08	66	70T1504	31	71T9650	18
175H7190	41,44,49	38N358C.10	66	70T5550.TL	12	71T9680	18
175H9100	49	38N358C.12	66	70T5580.TL	12	71T9690B	18,34,37,40,44
175H9130	49	38N358CE08	66	70T5590BTL	12	71T9750	18
175H9160	37-39,42-44,49	38N358CE08	66	70T5650.TL	12	71T9780	18
175H9190	37,39-44,49	39C355C.16	68	70T5680.TL	12	71T9790B	18,34,37,41,44
175H9190.22	37, 40,41,44,49	39C355C.20	68	70T5690BTL	12	72T5550.TL	13
175L6030.21	51	39C355C.21	68	70T6540B	14	72T550A.TL	21
175L6600.22	51	39C355C.22	68	70T6550	14	72T5580.TL	13
175L6600.24	51	39C355C.24	68	70T6580	14	72T5590BTL	13



Part no.	Page No.				
73T550A	21	90M2103	31, 59	MZM.0019	83
73T550AB	20	90M2203	31	MZM.0021	83
73T5550	13	90M2550	54	MZM.0037	83
73T5550.22	16	90M2580	54	MZM.0038	83
73T5580	13	91A6550	55	MZM.0383	83
73T5580.22	16	91A6580	55	MZM.0050	83
73T5590B22	16	91A6650	55	MZR.5300.US	81,82,84
73T558E	13	91A6680	55	MZR.2000	84
73T5590B	13	91M2550	54	MZS.1000	84
74.1103	31	91M2580	54	MZS.1020	82,84
74T1550.TL	11	91M2650	54	MZS.2000	84
74T1580.TL	11	91M2680	54	MZS.3000	84
74T1590BTL	11	91M2750	54	MZW.1300	75
75M1550	29	91M2780	54	POZI BIT #2x1	79
75M1580	29	94M3203	31,59	POZI BIT #2x2	79
75M1650	29	BIT HOLDER	79	POZI DRIVER	79
75M1680	29	DB-2mm	85	SJ5312	79
75T1550	11	DB-10mm	85	T108-10mm L	85
75T1580	11	DB-10x2mm	85	T108-10mm R	85
75T1590B	11	DB-2.5mm	78,85	T108-8mm L	85
75T1650	11	DB-5mm	76-78,85	VPB-5	85
75T1680	11	DB-8mm	78,85		
75T1690B	11	FX4041	79		
75T1750	11	M01.ZB05.D3 L	85		
75T1780	11	M01.ZB05.D2 R	85		
75T1790B	11	M01.ZB08.03 L	85		
75T4100	26	M01.ZB10.03 L	85		
75T4200	26	M01.ZB10.02 R	85		
75T4300	26	M01.ZB20.02 R	85		
79A5490BT	34,37,43,44	M01.ZB35.02 R	85		
79A5491BT	34,37,43,44	M30.0212	84		
79A5493BT	34,37,43,44	M30.1304	84		
79A9494BT	34,37-41	M31.1000	75		
79A9496BT	34,37,38,40	M31.ZB08.03	75		
79A9498BT	34,37-39	M31.ZB35.02	75		
79A9595BT	34,37,39,41,42	M52.1056.US	82		
79A9596BT	34,37,39-42	M53.0720.US	81,82,84		
79A9698BT	34,37,40-42	M53.1004.50	82		
79T5550	23	M53.1004.US	81		
79T5580	23	M53.1005.50	82		
79T5590B	23,34,37,39,41	M53.1005.US	81		
79T8500.10	26	M53.1053.UB	81		
79T8530.10	26	M53.1053.US	81		
79T9550	22	M53.1053.50	82		
79T9580	22	MZA.1000	84		
79T9590B	22	MZA.5300	84		
79T9950.37	24	MZE.2110	81, 82, 84		
79T9980.37	24	MZK.1000.US	83		
79T9990B37	24	MZK.8000.US	83		
80.6107	31, 59	MZK.200-90	84		
80.6507	31	MZL.1250.US	84		
834TH	66-68,71,79	MZM.0010	83		
84.4120	26	MZM.0011	83		
84.4140	26	MZM.0018	83		

Quick reference

Hinge cup centerpoint

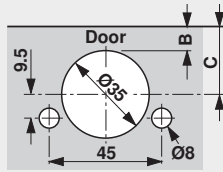

C Cup centerpoint						
20.5	21.5	22.5	23.5	24.5	25.5	
13/16"	27/32"	7/8"	15/16"	31/32"	1"	
3	4	5	6	7*	8*	
B Bore distance						

* only for use with select Blum hinges

Conversion Chart

Inch	mm
1/32	.031
1/16	.063
3/32	.094
1/8	.125
5/32	.156
3/16	.188
7/32	.219
1/4	.25
9/32	.281
5/16	.313
11/32	.344
3/8	.375
13/32	.406
7/16	.438
15/32	.469
1/2	.5
17/32	.531
9/16	.563
19/32	.594
5/8	.625
21/32	.656
11/16	.688
23/32	.719
3/4	.75
25/32	.781
13/16	.813
27/32	.844
7/8	.875
29/32	.906
15/16	.938
31/32	.969
1	1
	25.4

Hinges per door

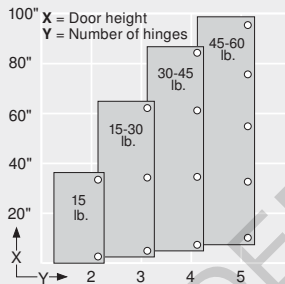

This chart can serve as a guide for determining the number of hinges per door. Note that door weight can also determine the number of hinges required.

* The distance between the two hinges must be greater than the width of the door for maximum stability.

Hinge abbreviation key

CLIP top, CLIP, and MODUL

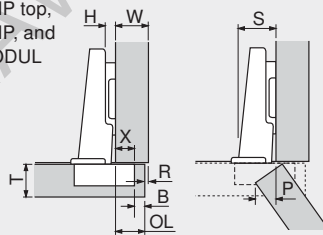

COMPACT

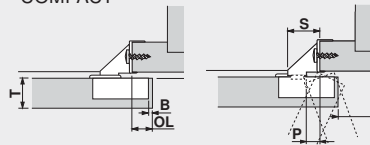

- B** = Boring distance
- H** = Mounting plate height
- OL** = Door overlay
- P** = Door protrusion (at max. opening)
- R** = Reveal
- S** = Hinge arm protrusion
- T** = Door thickness
- W** = Side panel width
- X** = Fixed cup distance

Fixed distance (X)

The distance that the cup overlays the cabinet side panel when a hinge is attached to a 0mm mounting plate. This is used to calculate hinge Overlay with the formula $X + B - H = OL$ (Fixed Distance + Boring Distance - Mounting Plate height = Overlay).

DRAWERDEPOT.COM

Blum, Inc.
7733 Old Plank Rd.
Stanley, NC 28164
800-438-6788
704-827-1345
fax 704-827-0799
www.blum.com

