

Hinge assembly

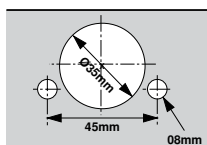

ECODRILL



Blum hinge boring pattern

- Simple device for boring Blum hinge pattern
- Driven by electric/cordless drill (14v or better)
- Each drill bit is driven separately and retracts automatically
- Variable boring distance from 2mm to 8mm
- Clamps to various door thicknesses up to 40mm (1-9/16")
- Includes drill bits (pre-installed) and two Torx driver bits

Part no.

ECODRILL

M31.1000

ECODRILL and Torx bits (included)

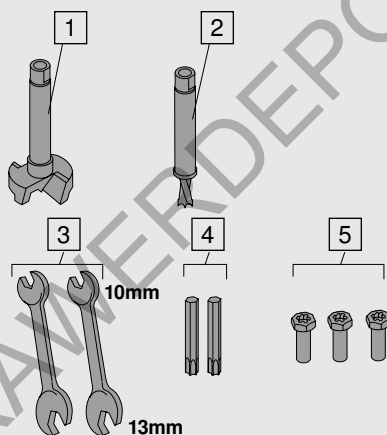
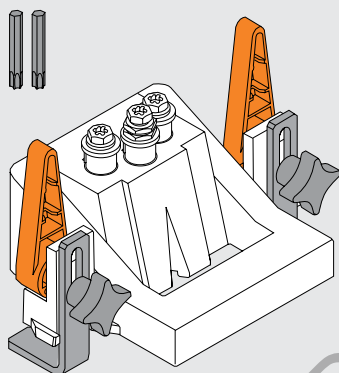

Replacement drill bits

- | | |
|---|-----------------|
| 1 | Ø35mm drill bit |
| 2 | Ø8mm drill bit |

Tool Set

- | | |
|---|--------------------|
| 3 | 2 wrenches |
| 4 | 2 Torx driver bits |
| 5 | 3 Torx chucks |

Accessories (order separately)

- | | | | | |
|---|-----------------|---|---|----------|
| 1 | Ø35mm drill bit | | | |
| 2 | Ø8mm drill bit | | | |
| 3 | 4 | & | 5 | Tool set |

Part no.

M31.ZB35.02

M31.ZB08.02

MZW.1300

Using the ECODRILL

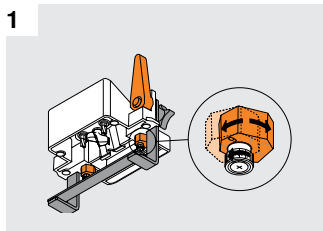

1 Set boring distance cams by rotating to the desired position.

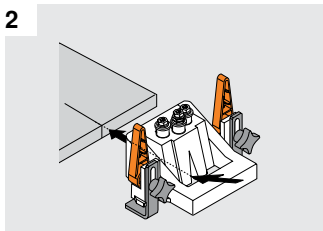

2 Align ECODRILL body with hinge center line marked on the door.

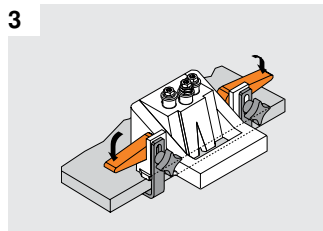

3 Secure ECODRILL to the door by pushing the clamp arms down.

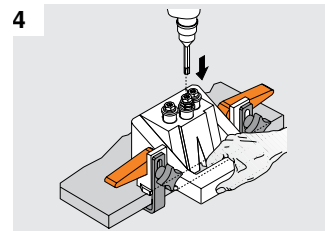

4 With the Torx bit inserted into the drill chuck, bore the three holes separately.